

PERFORMANCE IS IN OUR DNA

High performance special steels
and technology for food industry

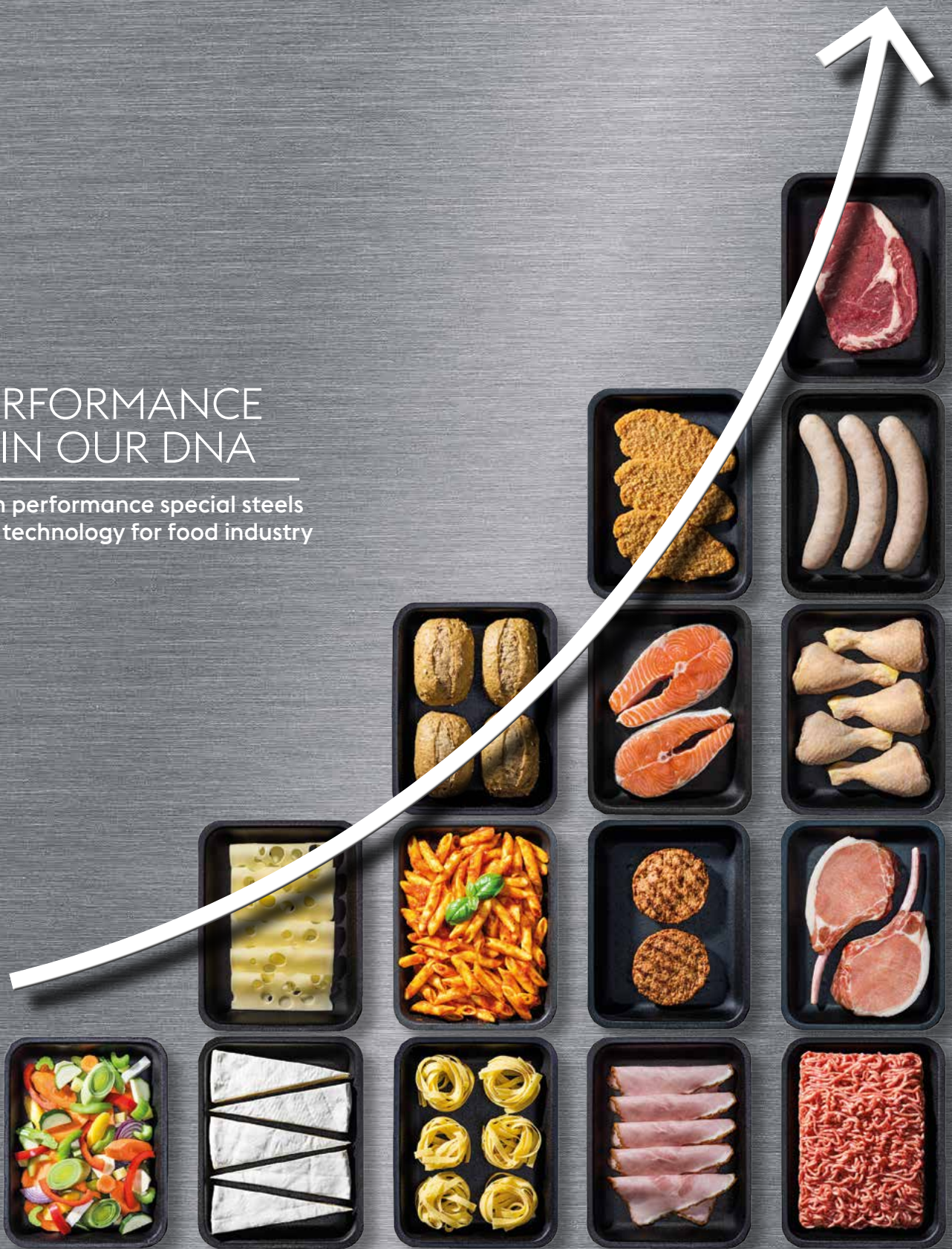



WHO WE ARE AND WHAT WE DO

voestalpine WORLD-WIDE

The voestalpine group, headquartered in Linz, Austria, is a globally leading steel and technology group with a unique combination of materials and processing expertise.

With its top-quality products and system solutions made from steel and other metal alloys, it is a leading partner to the European automotive and consumer goods industries as well as the global aerospace and oil & gas industries; it is also the world market leader in railway systems, tool steel, and special sections.

Steel from voestalpine can be found in many impressive places, like the latest generation of Airbus aircraft, the Atomium in Brussels, at Wembley stadium in London, or in the world's tallest building – the Burj Khalifa in Dubai.



HIGH PERFORMANCE METALS DIVISION

As the global market leader in tool steel and one of the leading suppliers of high-performance materials, voestalpine High Performance Metals produces technologically advanced products at eight production sites in Europe, North and South America. And with 140 locations in 40 countries on every continent, we provide our customers with outstanding service wherever they may be located. We offer our customers production, sales, and service from a single source. Our core business is defined in two areas:

1. HPM (High Performance Metals) Production

Production includes:

- » Tool steel & High-speed steel
- » Valve steel
- » Engineering steel
- » Powder metallurgy-produced steels
- » Powder for additive manufacturing processes
- » Special steels

We also manufacture die-forged parts: titanium alloys, nickel-based alloys, and high, medium, low alloy steels.

Many of our customers belong to the most technologically demanding industries, and they are served by our marketing-leading brands **BÖHLER**, **UDDEHOLM**, **Buderus Edelstahl** and **Villares Metals** for special steels, tool steels, powder metallurgical steels and additive manufacturing powders.



2. Value Added Services (Sales with Special Services)

We are committed to fostering long-term partnerships with our customers throughout their value chain – starting with concept and design, selection of the right materials, and following through to include production and post-production services. These post-production services include:

- » Sawing & Machining
- » Heat treatment & Coating
- » Surface treatment
- » Additive Manufacturing

Our state-of-the-art heat treatment services include a range of methods, from vacuum hardening to plasma nitriding. Our experts at voestalpine eifeler Coating have been optimizing tool surfaces through various coating techniques (such as PVD coating) and setting the industry standard since 1983. Eschmann Textures is one of the world's leading suppliers in the field of surface treatment, using advanced engraving techniques for aesthetical and functional purposes.

Regardless of our brand or location, our sales team works closely with engineers, toolmakers and machine manufacturers, to offer our customers complete solutions. Customer intimacy and effective logistics are an integral part of our commitment to fostering long-term partnerships with our customers.

Ready-to-Use Engineered Products

Our range of ready-to-use Engineered Products are absolute game changers when it comes to optimizing productivity, reducing total cost of ownership, and minimizing CO₂ emissions. Created through both additive manufacturing (3D printing) and conventional manufacturing, our Engineered Products are focused on the following industries:

- » Food and Beverage
- » Plastic Injection Molding
- » High Pressure Die Casting

From Meat Grinding Technology for the Food and Beverage Industry to Inserts for Cylindrical Containers for the Plastic Injection Molding Industry, these Engineered Products can be tailor-made according to our customers' needs. The innovative production and post-production technology that is behind these products integrates our two core business areas: Production and Value Added Services.



To find out more about our [Engineered Products](#) for the food industry, please watch our image video.



STATE-OF-THE-ART FOOD PRODUCTION NEEDS HIGH PERFORMANCE MATERIALS OF THE HIGHEST QUALITY

THE LATEST TECHNOLOGY AND NEWEST ENVIRONMENTAL STANDARDS

At our production sites – in Hagfors in Sweden and Kapfenberg as well Mürtzuschlag in Austria – we set new standards for production quality, process reproducibility, and environmental impact. In addition to using resources responsibly, we are constantly implementing new measures for environmentally friendly processes and production.

Sustainable production processes and the use of the best possible environmentally friendly technologies have been an essential part of our environmental philosophy for decades.

HIGHEST PRODUCTION QUALITY

Safe, efficient production lines with minimum down-time are of great importance in the food industry around the world. Our state-of-the-art production processes such as protective gas electroslag remelting or powder metallurgy enable us to fulfil the highest quality standards.

As the world's leading manufacturer of tool steels, we have tested our high performance materials specifically for the food industry and work together closely with our customers in these demanding applications.

Our special steels for the food industry are safe food contact materials due to their high cleanliness and their corrosion resistance, and have no influence on the taste of any food they are in contact with.





OUR HIGH PERFORMANCE STEELS FOR THE FOOD INDUSTRY

HIGH DEMANDS

The industrial processing of food places high demands on the tools and food contact materials used.

High hardness and wear resistance are required, as well as absolute safety regarding potential health risks which could occur due to contaminations of food stuffs through food contact materials. The deciding criterion here is a high resistance to migration of elements from the steel into food.

We continually carry out quality controls to ensure consistent quality of our steel products. In addition, we carefully test the behaviour of our products in contact with food, so that consumers' concerns about safety can be eliminated.

TESTING LABORATORIES / ANALYSES

The state-of-the-art laboratories at our production sites provide important information and product parameters for process control and product certification in accordance with international standards and customer specifications.

For food industry tests, we work together with accredited external laboratories.

Since there are a number of different national regulations regarding food contact materials, the Council of Europe has published a guideline for the evaluation of safety in contact with food. This technical documents "metals and alloys used in food contact materials" lists acceptable limits for metal migration alongside the testing parameters and food simulant media to be used.

AGES and Normpack have tested our high performance steels and certified them as in accordance with Council of Europe expectations.





BÖHLER MATERIALS PORTFOLIO

CERTIFIED ACCORDING TO REGULATION (EC) NO. 1935/2004 BY AGES

BÖHLER Grades	Heat treatment parameters			Test conditions	
	Austenization temperature TA [°C]	Tempering temperature (2x 2h) TT [°C]	Hardness HRC	Tap water DIN 10531 100°C, 2 hours	Citric acid 5 g/l 40°C, 10 days
				Test represents use in weakly acidic and mildly salty media	Test represents long-term use in acidic media
M333 ISOPLAST	980/1000	250	51/52	✓	✓
M333 ISOPLAST	980/1000	525	48	✓	x
M340 ISOPLAST	1000	250	56	✓	✓
M340 ISOPLAST	1000	525	53	✓	x
M368 MICROCLEAN	1000	250	53	✓	✓
M368 MICROCLEAN	1000	525	52	✓	x
M380 ISOPLAST	1020***	200	58	✓	✓
M380 ISOPLAST	1120***	520	57	✓	-
N360****	1020***	200	58	✓	✓
M390 MICROCLEAN	1150	250	58	✓	x
M390 MICROCLEAN	1150	525	60	✓	x
M303 EXTRA	prehardened		30	✓	✓
N690	1050	150	60	✓	x
M315 EXTRA	prehardened		30	✓	x
M789 AMPO	1000	500*	52	✓	✓
N700 AMPO	1040	510**	40	✓	✓
N680****	1020***	200	58	✓	✓

* Precipitation hardened 1 x 3 hours
 ** Precipitation hardened 1 x 4 hours
 *** Treated by sub-zero-treatment after hardening
 **** Only available in sheet form

✓ Specific release limits not exceeded
 x Specific release limits exceeded
 - Not tested



UDDEHOLM MATERIALS PORTFOLIO

CERTIFIED ACCORDING TO REGULATION (EC) NO. 1935/2004 BY NORMPACK

Uddeholm Grades	Food type				
	Dry	Aqueous	Acidic	Alcohol	Fatty
Caldie	✓	-	-	-	✓
Corrax	✓	✓	✓	✓	✓
Dievar	✓	-	-	-	✓
Bure	✓	-	-	-	✓
Elmax SuperClean (low tempered)	✓	✓	-	✓	✓
Idun	✓	✓	-	✓	✓
Impax Supreme	✓	-	-	-	✓
Mirrax 40	✓	✓	-	✓	-
Mirrax ESR (low tempered)	✓	✓	✓	✓	✓
Nimax	✓	-	-	-	✓
Orvar 2 Microdized	✓	-	-	-	✓
Orvar Supreme	✓	-	-	-	✓
Ramax HH	✓	✓	-	✓	✓
Rigor	✓	-	-	-	✓
RoyAlloy	✓	✓	-	✓	✓
Sleipner	✓	-	-	-	✓
Stavax ESR	✓	✓	-	✓	✓
Sverker 21	✓	-	-	-	✓
Tyrax ESR (low tempered)	✓	✓	-	✓	✓
Unimax	✓	-	-	-	✓
Vanadis 4 Extra SuperClean	✓	-	-	-	✓
Vanadis 8 SuperClean	✓	-	-	-	✓
Vanax SuperClean	✓	✓	✓	✓	✓



PORTFOLIO OF HIGH PERFORMANCE MATERIALS AND FREQUENT PRODUCT SHAPES

PORTFOLIO

Stainless steel

for applications where corrosion-resistance is a must. Our stainless steels go far beyond 304 and 306 types for increased hardness, wear resistance and/or toughness.

Tool steel & High speed steel

corrosion-resistant or non-corrosion-resistant grades for use where wear resistance, high hardness and/or high-temperature performance are required.

Knife steels

for hand knives , moulds and other tooling-type applications. Corrosion-resistant and non-corrosion resistant grades, many with food safety certificates.

Special engineering steels

for use e.g. in gearboxes and other engineering applications.

Powder for additive manufacturing

supreme-quality powder in stainless steel and tool steel grades for use in 3D printing processes.

Engineered Products

tailor-made ready-to-use components and spare parts for a range of applications.

PRODUCT SHAPES

Bar steel round

peeled, polished, ground, pre-machined

Flat bars

machined, ground

Precision wire

flat, round

Blocks

sawn, machined

Sheet and plate

cross-rolled, hot rolled, cold rolled, blanks and press plates

Powder for additive manufacturing

container size 10 kg

Forgings

open die forgings, black or machined

Rolled rings

hot rolled and turned

Rolled wire

in rings



APPLICATIONS AND SEGMENTS EXCERPT



Meat Processing

Meat grinding kits for stuffing machines made of premium materials including PVD-coating.

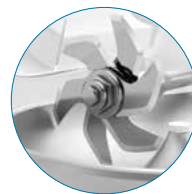

Sausage production

Bowl cutter knives made of cross-rolled, corrosion resistant premium plates with tailored heat treatment

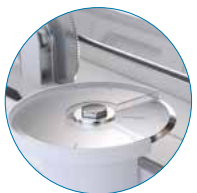

Chicken processing

Chicken processing knives made of cross-rolled, corrosion resistant premium plates with tailored heat treatment for the right hardness level



Food extrusion

Corrosion resistant steels with tailored heat treatment for the right hardness level

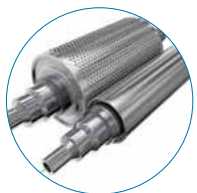

Grain processing

Steel rolls for cereal production made of premium electro slag remelted (ESR) tool steel grades

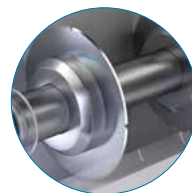

Film cutting

Film cutter knives made of premium materials including heat treatment and final machining



Can closing

Corrosion resistant premium materials for can closing rolls with tailored heat treatment for the right hardness level

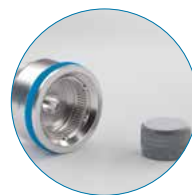

Bottle caps

Premium materials for injection moulds, f.ex. for the production of capping chucks for bottling

MEAT GRINDING TECHNOLOGY FOR STUFFING MACHINES



Ready-to-use solution made of a combination of our premium-materials including PVD-coating.

DETAILS:

- » Several **high-performance metals** treated to the right hardness with/ without PVD coating for high wear resistance
- » voestalpine meat grinding technology for stuffed and minced meat, applicable for all industrial machine types
- » Dimensions on request (all standard and tailored sizes possible)
- » **Lead time: 10-12 weeks** depending on size & quantities, stock possible depending on order quantities

CUSTOMER VALUE:

- » Shorter drying time for raw sausages
- » Higher machine availability and efficiency
- » Significant reduced total costs of ownership
- » Extreme wear resistance
- » Less maintenance (regrinding) effort
- » Improved processing properties
- » Less product (meat) contamination
- » Improved cutting result

Regrinding interval in hours

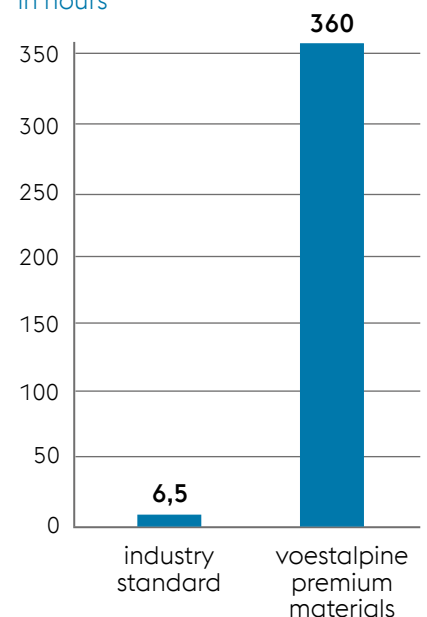

MEAT GRINDING TECHNOLOGY PRE-CUTTING

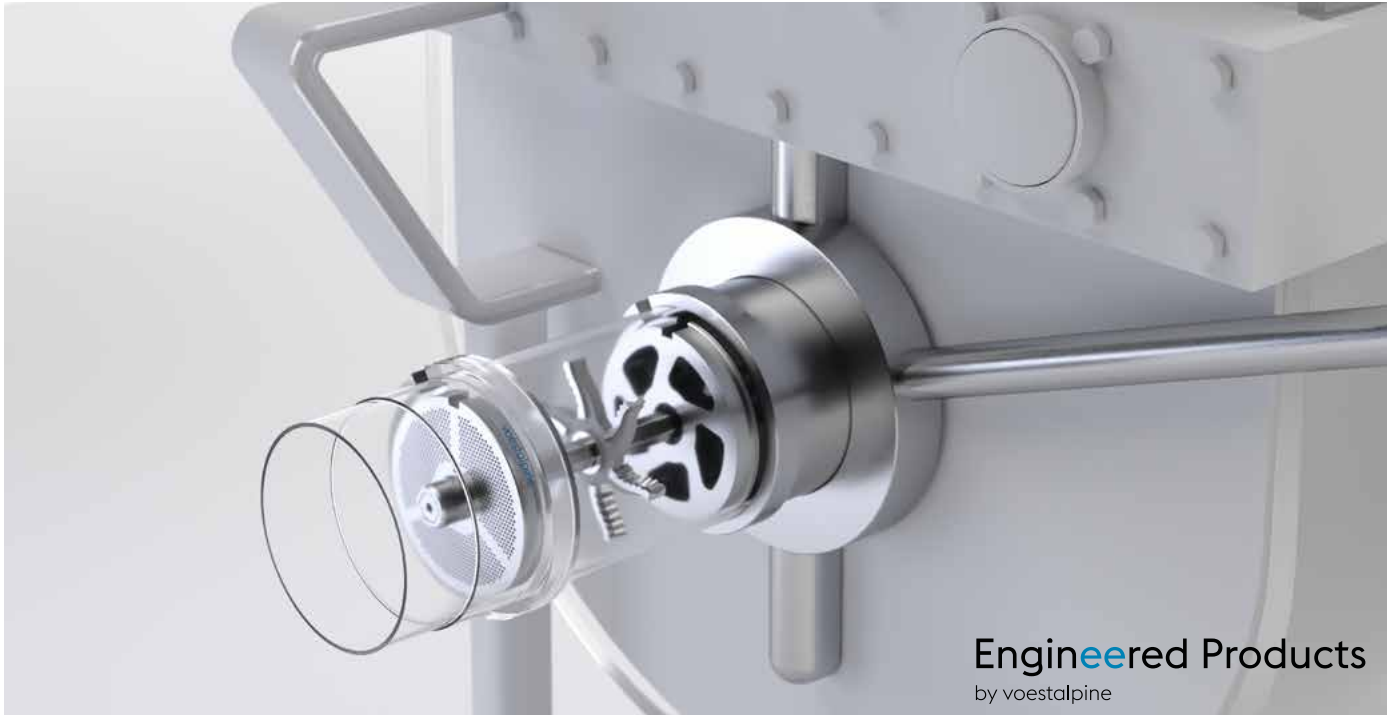

Ready-to-use solution made of a combination of our premium-materials including PVD-coating.

DETAILS:

- » Several **high-performance metals** treated to the right hardness with/without PVD coating for high wear resistance
- » Meat grinding technology applicable for all industrial machine types
- » Dimensions on request (all standard and tailored sizes possible)
- » **Lead time: 6-8 weeks** depending on size & quantities, stock possible depending on order quantities

CUSTOMER VALUE:

- » Higher machine availability and efficiency
- » Significant reduced total costs of ownership
- » Extreme wear resistance
- » Less maintenance (regrinding) effort
- » Improved processing properties
- » Less product (meat) contamination

Regrinding interval in hours

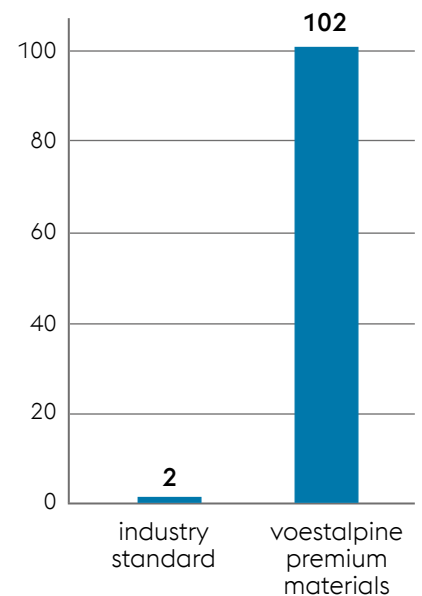

BOWL CUTTER KNIVES FOR SAUSAGE PRODUCTION

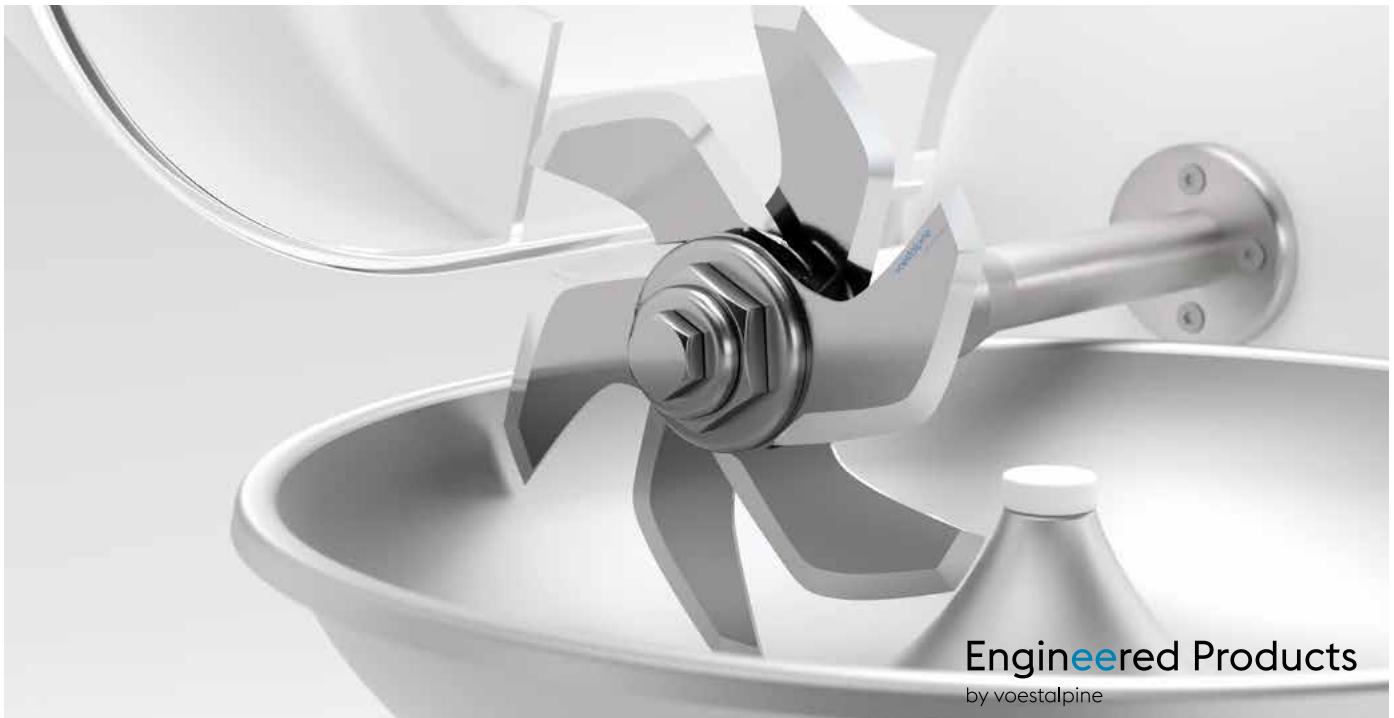

Ready-to-use bowl cutter knives for industrial meat cutter machinery are made of our premium materials with tailored heat treatment.

DETAILS:

- » Made of **cross-rolled, corrosion resistant premium material**, with tailored heat treatment for the right hardness level
- » voestalpine knives available for all standard machine types
- » All standard sizes available
- » **Lead time: 6-8 weeks** depending on size & quantities, stock possible depending on order quantities

CUSTOMER VALUE:

- » Longer lifetime compared to industry standard
- » Higher machine availability and efficiency
- » Ductility (safety against cracks)
- » Corrosion resistance
- » Outstanding balance of wear resistance
- » Significant reduced total costs of ownership
- » Less maintenance effort
- » Improved processing properties

Achieved throughput in 1,000 kg

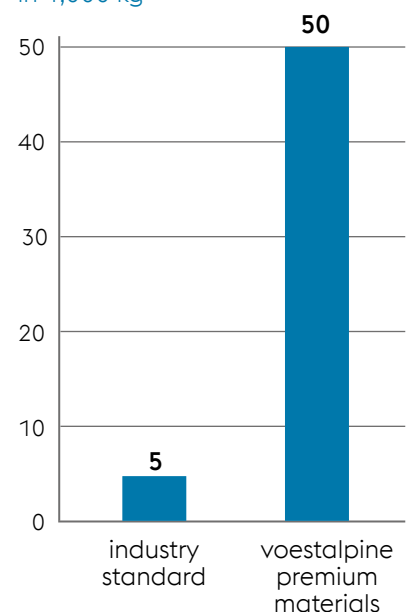

KNIVES FOR CHICKEN PROCESSING

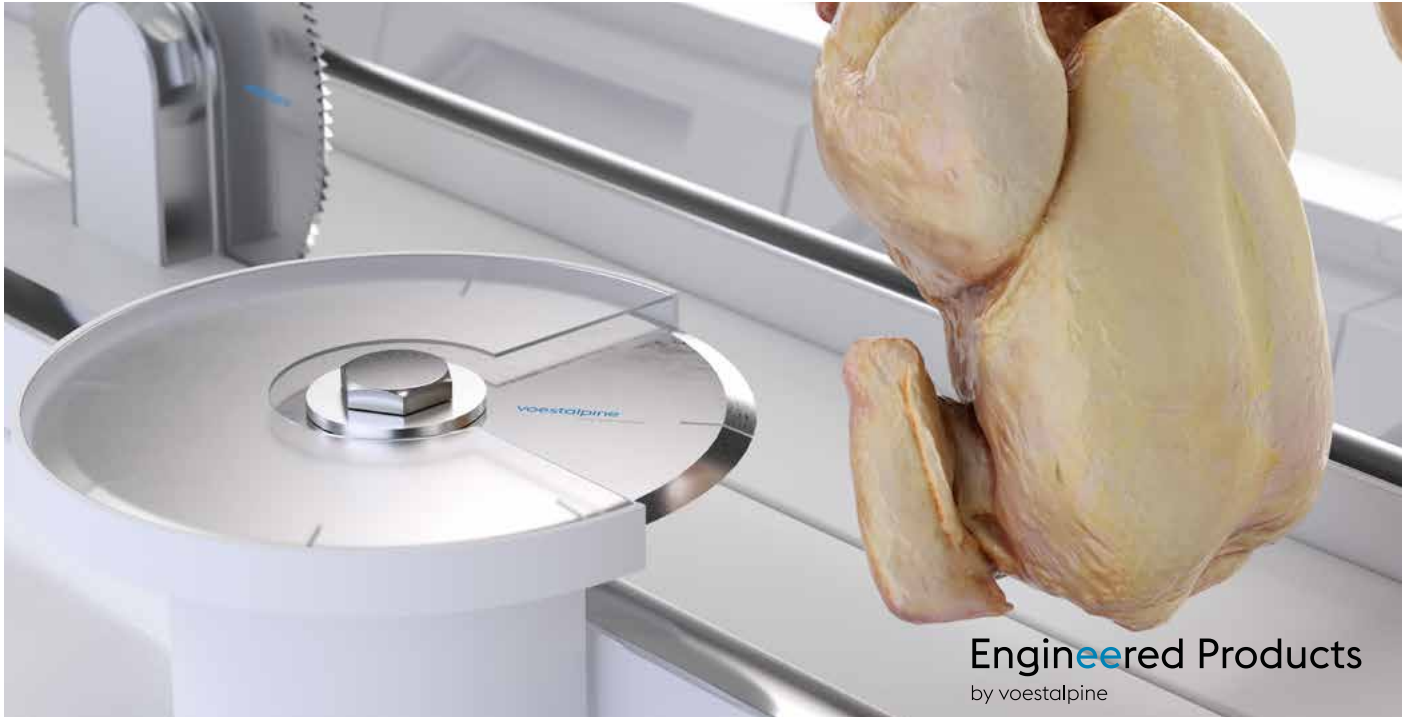

Engineered Products
by voestalpine

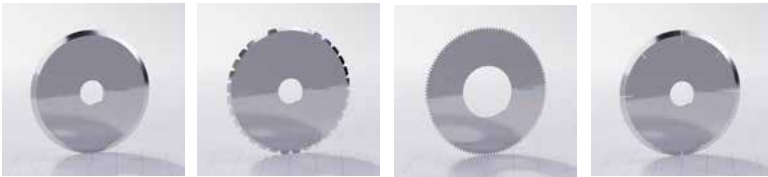

Ready-to-use chicken processing knives are made of our premium materials in combination with heat treatment and final machining.

DETAILS:

- » Made of **cross-rolled, corrosion resistant premium material**, with tailored heat treatment for the right hardness level
- » voestalpine chicken processing knives are applicable for all industrial machine types
- » Dimensions on request (all standard and tailored sizes possible)
- » **Lead time: 8-10 weeks** depending on size & quantities, stock possible depending on order quantities

CUSTOMER VALUE:

- » Longer lifetime compared to industry standard
- » Higher machine availability and efficiency
- » Significant reduced total costs of ownership
- » Outstanding balance of wear resistance
- » Less maintenance (regrinding) effort
- » Improved processing properties
- » Tailored solutions for individual requirements

Lifetime
in %

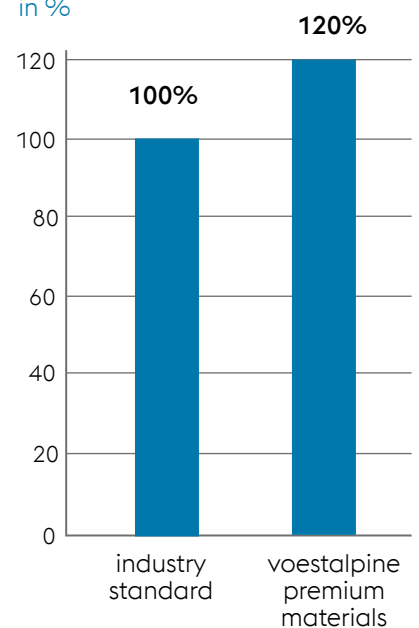

FILM CUTTER KNIVES FOR FOOD PACKAGING

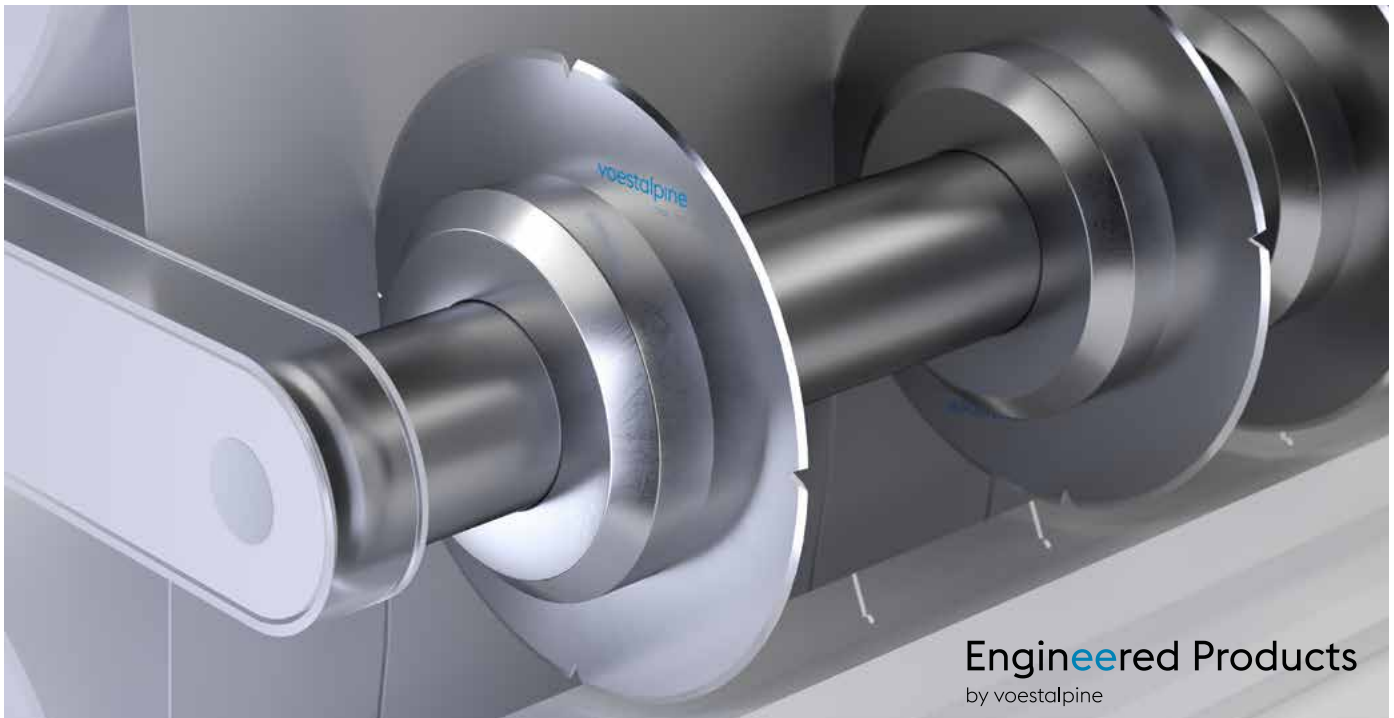

Engineered Products
by voestalpine



Ready-to-use film cutter knives are made of our premium materials including tailored heat treatment and final machining.

DETAILS:

- » Made of **premium tool steels & high speed steels** with tailored heat treatment to the right hardness and final machining
- » voestalpine film cutter knives (horizontal and round knives) are applicable for all industrial machines types
- » Dimensions on request (all standard and tailored sizes possible)
- » **Lead time: 8-10 weeks** depending on size & quantities, stock possible depending on order quantities

CUSTOMER VALUE:

- » Longer lifetime compared to industry standard
- » Improved processing properties
- » Higher machine availability and efficiency
- » Higher productivity
- » Significant reduced total costs of ownership

Lifetime
in %

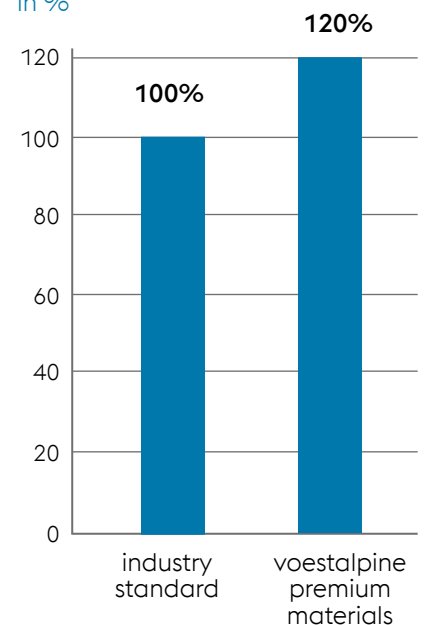

HIGH PERFORMANCE METALS FOR BOTTLE CAPS



voestalpine premium materials for injection moulds, f.ex. for the production of capping chucks for bottling (plastic caps).

DETAILS:

- » Premium-materials with tailored heat treatment to the right hardness level.
- » Surface: final machined
- » Dimensions on request
- » Lead time: depending on size & quantities

CUSTOMER VALUE:

- » Longer lifetime compared to industry standard
- » Improved processing properties (compressive strength, toughness)
- » Extreme wear and corrosion resistance
- » Good polishability
- » Significant reduced total costs of ownership

Lifetime
in working days

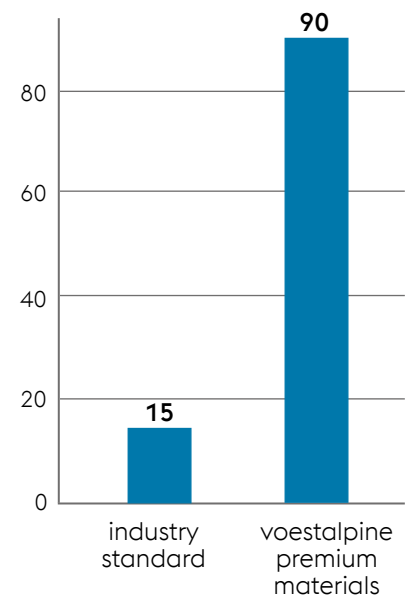

Contact



Kay Fisher

Head of
Food & Beverage Platform
High Performance Metals Division
Kay.Fisher@voestalpine.com
T: +43 50304 10 22528
Vienna, Austria



Josef Michailov

Senior Business Development
Food & Beverage Platform
High Performance Metals Division
Josef.Michailov@voestalpine.com
T: +49 151 25146916
Düsseldorf, Germany



Valentina Greul

Junior Segment Manager
Food & Beverage Platform
High Performance Metals Division
Valentina.Greul@voestalpine.com
T: +43 50304 10 22772
Vienna, Austria

voestalpine

ONE STEP AHEAD.