

JEILMEDICAL

Dual Top[®] ANCHOR SYSTEM

Self Drilling & Self Tapping



Contents

3	Indications
4	Features and Benefits
6	Procedures
	Ordering Information
12	- Dual Top Anchor System Screws
20	- Dual Top Anchor System Accessories
21	- Dual Top Anchor System Driver Shafts
22	- Anchor Plate System
24	- LIM Plate
26	- Orthonia



Dual Top[®] ANCHOR SYSTEM

Self Drilling & Self Tapping

Dual Top Anchor System is used to provide a fixed anchorage point for attachment of orthodontic appliances to facilitate the orthodontic movement of teeth. It is used temporarily and is removed after orthodontic treatment has been completed.

Screws are intended for single use only.

For use on adults over the age of 12.

Features and Benefits



Titanium Alloy Material

- Increased compatibility with CT and MRI
- Biocompatible, corrosion-resistant and non-toxic in a biological environment.

Thread Length Choice

For best fit of distal threads into far bone fragment to bear increased interfragmentary compression.

Self-Tapping Flutes

Reduced OR time by eliminating the need for tapping.

Immediate Loading

Dual Top works as an anchor for immediate loading

Collar for Gingiva Protection

Each screw has collar

No Incision and Flapping

Self-drilling and self-tapping allows no incision

Easy Removal

After the treatment, remove the screw by simple unscrewing

Applicable to Various Locations

It is small and can be implanted in different areas where needed.

Preparation

Determining the implant location

Use any metal device and x-ray image to determine the space between the roots of the teeth.



Metal Device



X-Ray Photo

Local anaesthesia

Local anaesthesia is required to insert Dual Top screws.

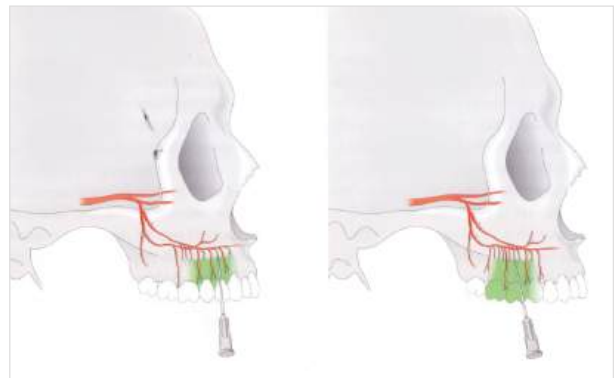

Screw pick-up

Use driver shaft and handle to pick-up



Use either manual shaft body or electric hand piece (sold separately)



Make sure screw is attached at correct angle for insertion

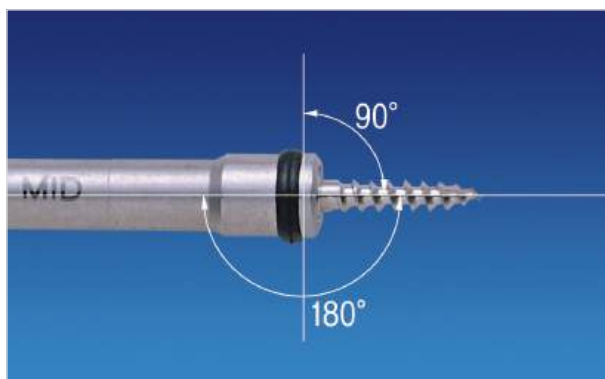

Required Instruments



Driver Shaft



Screwdriver Handle
111-010



Orthonia
111-ED-010



Orthonia
111-ED-040

Screw Insertion

Dual Top can be inserted without incision, flapping and drilling. Pre-drilling maybe required depending on bone density.

Push gently on driver body and rotate the gold part of the body clockwise.

Check the screw fixation by gently touching and pulling the screw.



Required Instruments



Driver Shaft



Screwdriver Handle
111-010

Optional

An electric handpiece can be used for the screw insertion.



Required Instruments



Orthonia
111-ED-010



Orthonia
111-ED-040

Palatal

Suitable for Mid-palatal suture area insertion.

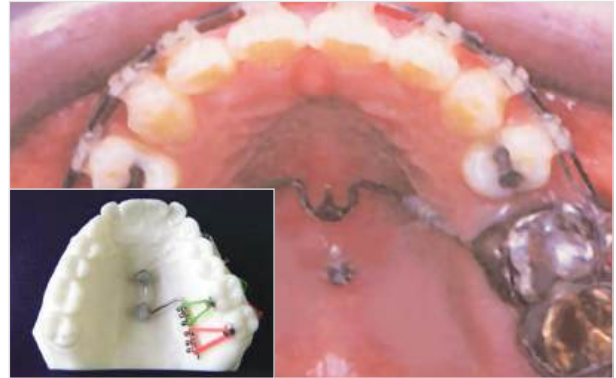

Maxilla

Suitable for attached gingiva insertion.



Mandible

Suitable for retromolar area, buccal shelf, or buccal alveolus insertion.



Dual Top Anchor System Screws

JA Screws

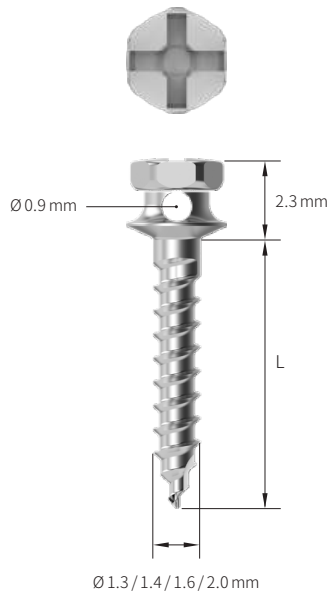

JA Screws with hole

Code	Outer Diameter	Length(L)
13-JA-005H	Ø 1.3 mm	5 mm
13-JA-006H	Ø 1.3 mm	6 mm
13-JA-008H	Ø 1.3 mm	8 mm
14-JA-006H	Ø 1.4 mm	6 mm
14-JA-008H	Ø 1.4 mm	8 mm
14-JA-010H	Ø 1.4 mm	10 mm
16-JA-005H	Ø 1.6 mm	5 mm
16-JA-006H	Ø 1.6 mm	6 mm
16-JA-008H	Ø 1.6 mm	8 mm
16-JA-010H	Ø 1.6 mm	10 mm
16-JA-012H	Ø 1.6 mm	12 mm
20-JA-005H	Ø 2.0 mm	5 mm
20-JA-006H	Ø 2.0 mm	6 mm
20-JA-008H	Ø 2.0 mm	8 mm
20-JA-010H	Ø 2.0 mm	10 mm
20-JA-012H	Ø 2.0 mm	12 mm

* SXX-JA-XXXH: Sterilized JA Screws with hole

JA Screws without hole

Code	Outer Diameter	Length(L)
14-JA-006N	Ø 1.4 mm	6 mm
14-JA-008N	Ø 1.4 mm	8 mm
14-JA-010N	Ø 1.4 mm	10 mm
16-JA-006N	Ø 1.6 mm	6 mm
16-JA-008N	Ø 1.6 mm	8 mm
16-JA-010N	Ø 1.6 mm	10 mm
20-JA-006N	Ø 2.0 mm	6 mm
20-JA-008N	Ø 2.0 mm	8 mm
20-JA-010N	Ø 2.0 mm	10 mm

* SXX-JA-XXXN: Sterilized JA Screws without hole

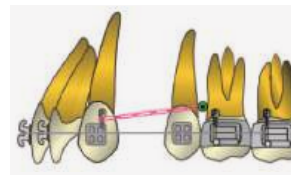

For elastic band

JB Screws

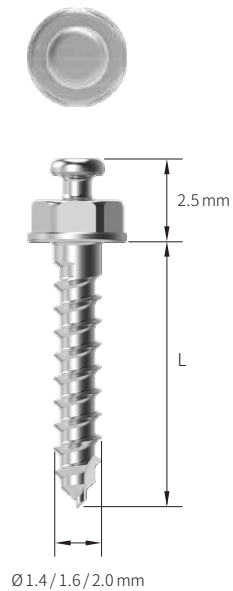
*JB Screws with hole*

Code	Outer Diameter	Length(L)
16-JB-006H	Ø 1.6 mm	6 mm
16-JB-008H	Ø 1.6 mm	8 mm
16-JB-010H	Ø 1.6 mm	10 mm
20-JB-008H	Ø 2.0 mm	8 mm
20-JB-010H	Ø 2.0 mm	10 mm
20-JB-012H	Ø 2.0 mm	12 mm

* SXX-JB-XXXH: Sterilized JB Screws with hole

JB Screws without hole

Code	Outer Diameter	Length(L)
14-JB-006	Ø 1.4 mm	6 mm
14-JB-008	Ø 1.4 mm	8 mm
14-JB-010	Ø 1.4 mm	10 mm
16-JB-006	Ø 1.6 mm	6 mm
16-JB-008	Ø 1.6 mm	8 mm
16-JB-010	Ø 1.6 mm	10 mm
16-JB-012	Ø 1.6 mm	12 mm
20-JB-006	Ø 2.0 mm	6 mm
20-JB-008	Ø 2.0 mm	8 mm
20-JB-010	Ø 2.0 mm	10 mm
20-JB-012	Ø 2.0 mm	12 mm

* SXX-JB-XXX: Sterilized JB Screws without hole



For elastic band

Dual Top Anchor System Screws

JF Screws

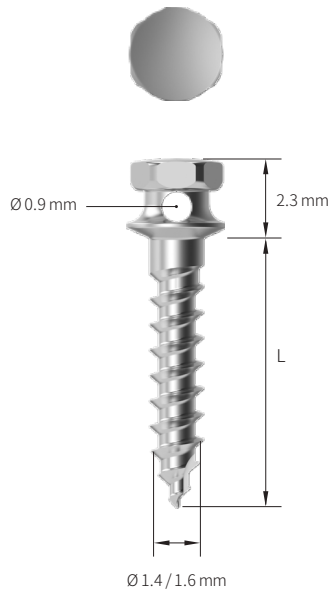

Code	Outer Diameter	Length(L)
14-JF-006	$\varnothing 1.4\text{ mm}$	6 mm
14-JF-008	$\varnothing 1.4\text{ mm}$	8 mm
16-JF-006	$\varnothing 1.6\text{ mm}$	6 mm
16-JF-008	$\varnothing 1.6\text{ mm}$	8 mm
16-JF-010	$\varnothing 1.6\text{ mm}$	10 mm

* SXX-JF-XXX: Sterilized JF Screws



Smooth head

G1 Screws

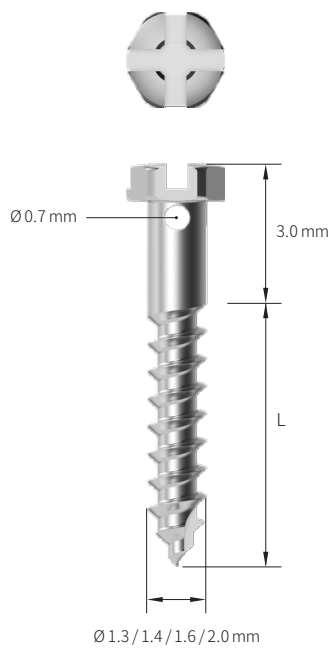

Code	Outer Diameter	Length(L)
13-G1-006	$\varnothing 1.3\text{ mm}$	6 mm
13-G1-008	$\varnothing 1.3\text{ mm}$	8 mm
14-G1-006	$\varnothing 1.4\text{ mm}$	6 mm
14-G1-008	$\varnothing 1.4\text{ mm}$	8 mm
16-G1-006	$\varnothing 1.6\text{ mm}$	6 mm
16-G1-008	$\varnothing 1.6\text{ mm}$	8 mm
16-G1-010	$\varnothing 1.6\text{ mm}$	10 mm
20-G1-006	$\varnothing 2.0\text{ mm}$	6 mm
20-G1-008	$\varnothing 2.0\text{ mm}$	8 mm
20-G1-010	$\varnothing 2.0\text{ mm}$	10 mm

* SXX-G1-XXX: Sterilized G1 Screws



For arch wire 0.022×0.028 Inch



G2 Screws

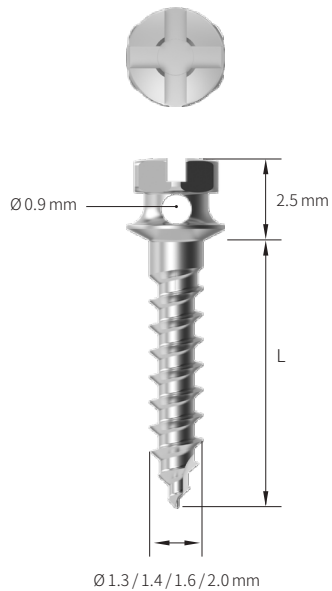

G2 Screws with hole

Code	Outer Diameter	Length(L)
13-G2-006	Ø 1.3 mm	6 mm
13-G2-008	Ø 1.3 mm	8 mm
14-G2-006	Ø 1.4 mm	6 mm
14-G2-008	Ø 1.4 mm	8 mm
14-G2-010	Ø 1.4 mm	10 mm
16-G2-006	Ø 1.6 mm	6 mm
16-G2-008	Ø 1.6 mm	8 mm
16-G2-010	Ø 1.6 mm	10 mm
16-G2-012	Ø 1.6 mm	12 mm
20-G2-005	Ø 2.0 mm	5 mm
20-G2-006	Ø 2.0 mm	6 mm
20-G2-008	Ø 2.0 mm	8 mm
20-G2-010	Ø 2.0 mm	10 mm
20-G2-012	Ø 2.0 mm	12 mm

* SXX-G2-XXX: Sterilized G2 Screws with hole

G2 Screws without hole

Code	Outer Diameter	Length(L)
14-G2-006N	Ø 1.4 mm	6 mm
14-G2-008N	Ø 1.4 mm	8 mm
14-G2-010N	Ø 1.4 mm	10 mm
16-G2-006N	Ø 1.6 mm	6 mm
16-G2-008N	Ø 1.6 mm	8 mm
16-G2-010N	Ø 1.6 mm	10 mm
20-G2-006N	Ø 2.0 mm	6 mm
20-G2-008N	Ø 2.0 mm	8 mm
20-G2-010N	Ø 2.0 mm	10 mm

* SXX-G2-XXXN: Sterilized G2 Screws without hole



For arch wire 0.022×0.028 Inch

Dual Top Anchor System Screws

JK Screws

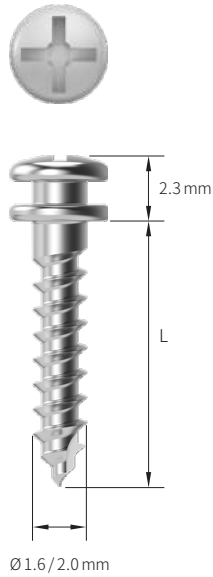

Code	Outer Diameter	Length(L)
16-JK-006	Ø 1.6 mm	6 mm
16-JK-008	Ø 1.6 mm	8 mm
16-JK-010	Ø 1.6 mm	10 mm
20-JK-006	Ø 2.0 mm	6 mm
20-JK-008	Ø 2.0 mm	8 mm
20-JK-010	Ø 2.0 mm	10 mm

* SXX-JK-XXX: Sterilized JK Screws

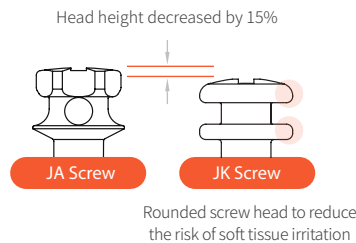

ANS Area

JD Screws

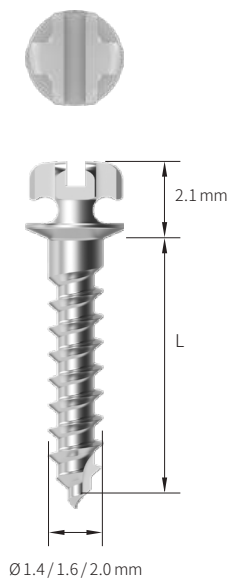

Code	Outer Diameter	Length(L)
14-JD-006	Ø 1.4 mm	6 mm
14-JD-008	Ø 1.4 mm	8 mm
14-JD-010	Ø 1.4 mm	10 mm
16-JD-006	Ø 1.6 mm	6 mm
16-JD-008	Ø 1.6 mm	8 mm
16-JD-010	Ø 1.6 mm	10 mm
20-JD-005	Ø 2.0 mm	5 mm
20-JD-006	Ø 2.0 mm	6 mm
20-JD-008	Ø 2.0 mm	8 mm
20-JD-010	Ø 2.0 mm	10 mm

* SXX-JD-XXX: Sterilized JD Screws



For arch wire 0.022×0.028 Inch



JO Screws

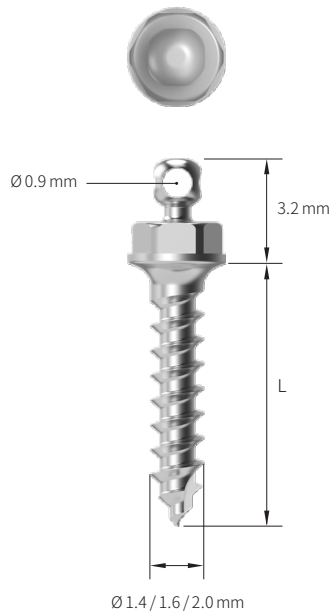

Code	Outer Diameter	Length(L)
14-JO-006	$\text{Ø } 1.4 \text{ mm}$	6 mm
14-JO-008	$\text{Ø } 1.4 \text{ mm}$	8 mm
16-JO-006	$\text{Ø } 1.6 \text{ mm}$	6 mm
16-JO-008	$\text{Ø } 1.6 \text{ mm}$	8 mm
16-JO-010	$\text{Ø } 1.6 \text{ mm}$	10 mm
20-JO-006	$\text{Ø } 2.0 \text{ mm}$	6 mm
20-JO-008	$\text{Ø } 2.0 \text{ mm}$	8 mm
20-JO-010	$\text{Ø } 2.0 \text{ mm}$	10 mm

* SXX-JO-XXX: Sterilized JO Screws



For arch wire 0.022×0.028 Inch

JS Screws

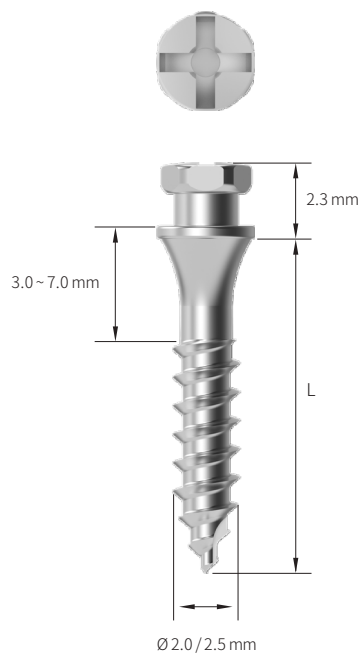

Code	Outer Diameter	Length(L)
20-JS-010	$\text{Ø } 2.0 \text{ mm}$	10 mm
20-JS-012	$\text{Ø } 2.0 \text{ mm}$	12 mm
20-JS-014	$\text{Ø } 2.0 \text{ mm}$	14 mm
25-JS-012	$\text{Ø } 2.5 \text{ mm}$	12 mm
25-JS-014	$\text{Ø } 2.5 \text{ mm}$	14 mm
25-JS-016	$\text{Ø } 2.5 \text{ mm}$	16 mm

* SXX-JS-XXX: Sterilized JS Screws



For molar distalization appliance

Dual Top Anchor System Screws

MIM Screws

Minimally Invasive Mini-Implant Screw

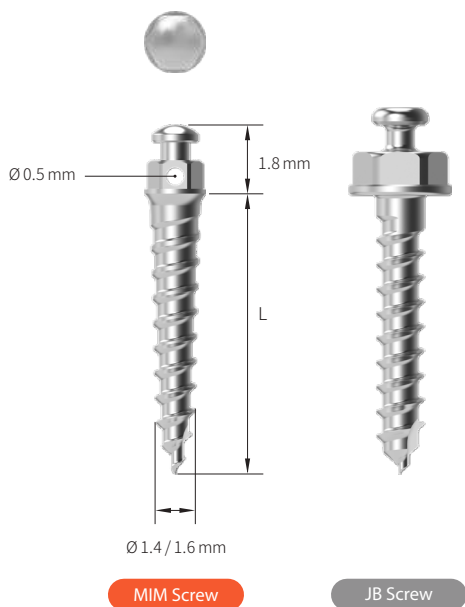

Code	Outer Diameter	Length(L)
14-MIM-006	Ø 1.4 mm	6 mm
14-MIM-008	Ø 1.4 mm	8 mm
16-MIM-006	Ø 1.6 mm	6 mm
16-MIM-008	Ø 1.6 mm	8 mm

* SXX-MIM-XXX: Sterilized MIM Screws



Anterior



Buccal



Palatal



Mid Palatal

Instruments

Containers



112-060



112-070



112-071



112-072



112-073

Code	Description	Set Quantity
112-060	Screw Block	1
112-070	Screw Block	1
112-071	Screw Block	1
112-072	Screw Block	1
112-073	MIM Block	1

Dual Top Anchor System Accessories

Impression Cap & JA / JD / G2 Screw Replica

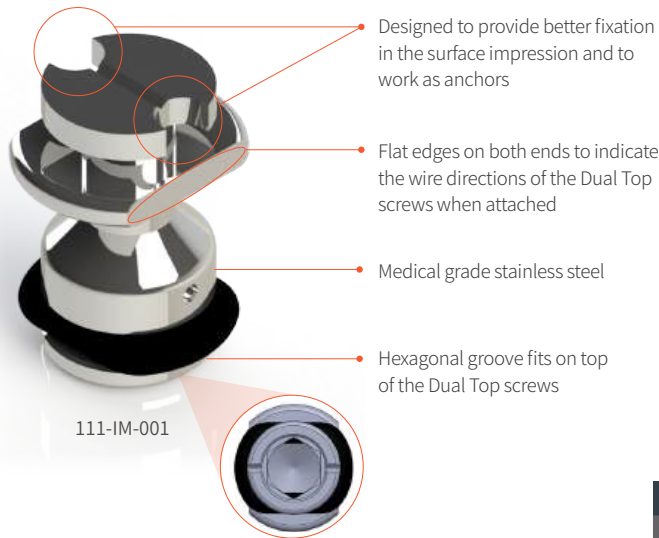

- Impression Cap(attachable on the screw head) & Replica Screws(with identical head shape)
- For More precise palatal wire fit & comfort for the patients
- Reflects exact position & angle of the actual screw inserted

Impression Cap & Replica Screws		
Code	Description	Quantity
111-IM-001	Impression Cap	1
111-RP-JA	JA Screw Replica	4pcs/pack
111-RP-JD	JD Screw Replica	4pcs/pack
111-RP-G2	G2 Screw Replica	4pcs/pack

How to use Impression Cap



Insertion of Dual Top screws in palatal area



Attach the impression caps on Dual Top screws



Perform surface impression of the patient

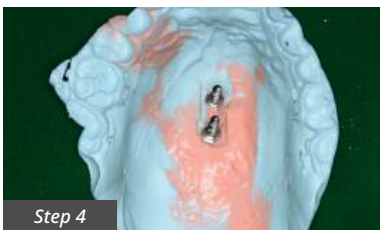

Check the location of the impression caps and attach the replica screws





















Use impression plaster to reconstruct palatal structure with replica screws



Use replica screws as abutments for making the palatal braces

Dual Top Anchor System Driver Shafts

Driver Shaft for Screwdriver Handle		Code	Applicable Screw										Length		
			JA	JB	JD	G1	G2	JK	JF	JO	JS	MIM			
		113-MJ-103	◆		◆			◆			◆		◆		70 mm
		113-JB-101		◆								◆		70 mm	
		113-MD-101	◆										◆	70 mm	
		113-NF-101							◆					70 mm	
		113-GD-101					◆	◆						70 mm	
		113-MIM-101											◆	70 mm	
Driver Shaft for Contra Angle		Code	Applicable Screw										Length		
			JA	JB	JD	G1	G2	JK	JF	JO	JS	MIM			
		113-MJ-203	◆		◆			◆		◆		◆		20 mm	
		113-MJ-204	◆		◆			◆		◆		◆		28 mm	
		113-MJ-202	◆		◆			◆		◆		◆		40 mm	
		113-JB-201		◆							◆			25 mm	
		113-JB-202		◆							◆			40 mm	
		113-MD-201	◆									◆		20 mm	
		113-NF-201							◆					20 mm	
		113-GD-201					◆	◆						20 mm	
		113-GD-211					◆	◆						40 mm	
		113-MIM-202											◆	40 mm	
		113-MIM-201											◆	20 mm	
Drill	Drill Bit Diameter (A)	Code	Applicable Screw										Length		
			JA	JB	JD	G1	G2	JK	JF	JO	JS	MIM			
	Ø 1.0 mm	112-MC-201	◆	◆	◆	◆	◆	◆	◆	◆	◆	◆	◆	28 mm	
Screwdriver Handle		Code	Applicable Screw										Length		
			JA	JB	JD	G1	G2	JK	JF	JO	JS	MIM			
		111-010	◆	◆	◆	◆	◆	◆	◆	◆	◆	◆	◆	110 mm	

Orthodontic Anchor Plate System

Anchor plates are made of pure titanium suitable for osseointegration and tissue integration. Anchor plates are developed to provide intraoral absolute anchorage for the intrusion or distalization of molars. Anchor plates do not disturb any kind of tooth movement because they are placed outside the dentition.

This is the most distinctive features of anchor plates in comparison with other orthodontic implant systems.

Biomechanics for molar movement

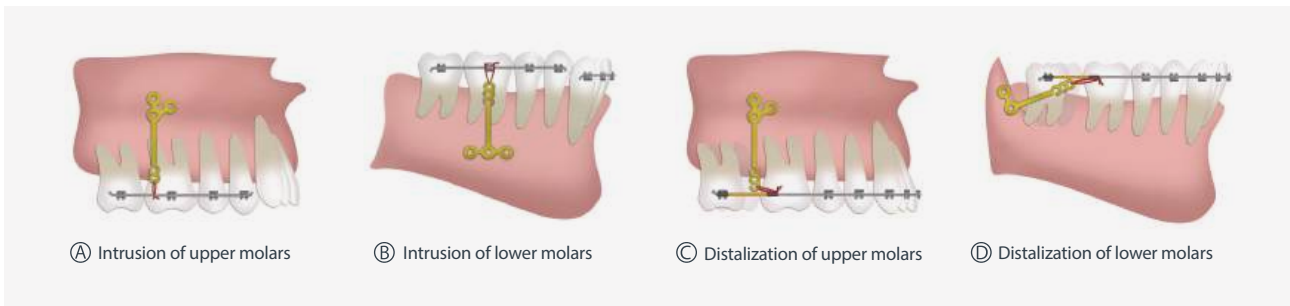

Anchor Plates

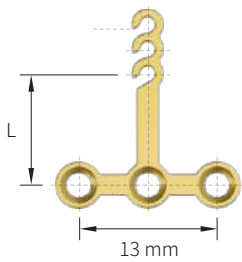

Code	Length(L)
AP-TL-010	10 mm
AP-TL-013	13 mm
AP-TL-016	16 mm

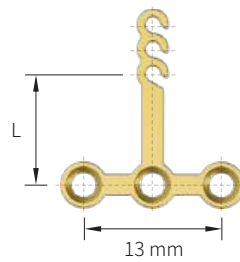

Code	Length(L)
AP-TR-010	10 mm
AP-TR-013	13 mm
AP-TR-016	16 mm

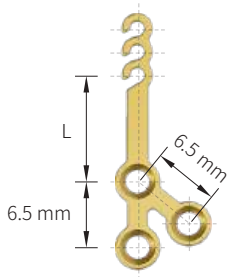

Code	Length(L)
AP-YL-010	10 mm
AP-YL-013	13 mm
AP-YL-016	16 mm

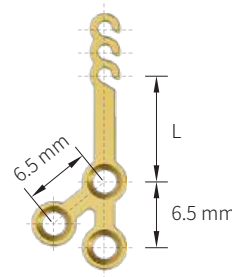

Code	Length(L)
AP-YR-010	10 mm
AP-YR-013	13 mm
AP-YR-016	16 mm

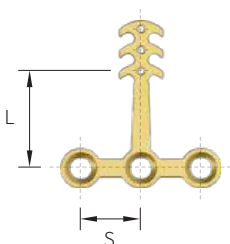

Code	Length(L)	Distance between holes(S)
AP-TS-010M	10 mm	5.75 mm
AP-TL-016M	16 mm	5.75 mm
AP-TM-013S	13 mm	5.0 mm
AP-TM-013M	13 mm	5.75 mm
AP-TM-013L	13 mm	6.5 mm

Orthodontic Anchor Plate System Screws

2.0 Auto Screws (Self-drilling)

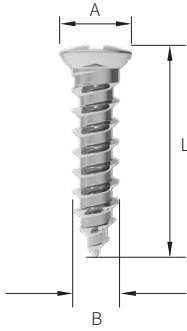

Code	Head Diameter(A)	Screw Diameter(B)	Length(L)
20-AT-004	Ø 3.0 mm	Ø 1.95 mm	4 mm
20-AT-006			6 mm
20-AT-008			8 mm
20-AT-010			10 mm
20-AT-012			12 mm

*Cruciate-Slot, Self-Drilling, Self Tapping

Instruments

Screwdriver Handle



Code	Description
111-010	Screwdriver Handle

Screwdriver Shaft & Drill Bit



113-MN-101



112-MN-201

Code	Description
113-MN-101	Screwdriver Shaft
112-MN-201	Drill Bit for 2.0 Auto Screws (Self-drilling)

Anchor Plate Block



Code	Description
112-062	Anchor Plate Block

LIM(Lingual Irritation-free Mini) Plate

A systemized Temporary Anchorage Device (TAD) for orthodontic tooth movement

- Applicable for complex and multidirectional traction forces
 - No interference with tooth movement
 - No damage to root
 - No incision
 - Self-Drilling screws / No pilot hole drilling
 - No irritation to palatal mucosa
 - Minimized tongue irritation / No speaking difficulties
- LIM (Lingual Irritation-free Mini) plate system

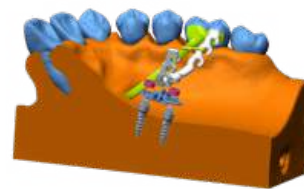
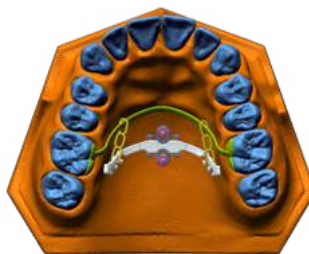

Bracket Plate System



AP-BK-010



AP-BK-012



AP-LV-038



AP-LV-040T



Example of using

Code	Description	Set Quantity
AP-BK-010	Bracket Plate, 0.032" X 0.040"Slot, Short type, Width: 10 mm	6
AP-BK-012	Bracket Plate, 0.032" X 0.040"Slot, Regular type, Width: 12 mm	6
AP-LV-038	Lever Plate, Length 38 mm	3
AP-LV-040T	Lever Plate, Length 40 mm, Tube type for rectangular wire 0.018" x 0.025"	3

Lever Plate System



AP-LP-038



AP-LP-040T

Code	Description	Set Quantity
AP-LP-038	Length 38 mm	3
AP-LP-040T	Length 40 mm, Tube type for rectangular wire 0.018" x 0.025"	3

Screws

2.0 Self-Drilling Screws with Nut

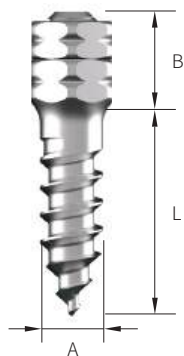

Code	Screw Diameter(A)	Head Length (B)	Length(L)	Set Quantity
20-LS-006	Ø 2.0 mm	2.35 mm	6 mm	6
20-LS-008			8 mm	6



Instruments

LIM Screwdriver Shaft



Code	Description	Set Quantity
113-LS-201	LIM Screwdriver Shaft for LIM Screw & Nut, Contra Angle Type, Length: 30 mm	1

LIM Block



Code	Description	Set Quantity
112-079	LIM Block for implants and instruments	1

Orthonia

A highly efficient battery-powered torque driver for the Dual Top screws. Helps to prevent screw breakage.

Driver Holder



Angle Type

- Easy approach to difficult areas to reach
- 360° degree rotation of handpiece
- Reduction of chair time (Sold Separately)

111-AN-020



Straight Type

- Accurate rotation axis
- No wobbling rotation
- High success rate of mini implant fixation
- Accurate torque limit control
- Prevention of screw fracturing

Specification

111-ED-010

Protection	Type BF, Battery-powered
Rated Voltage	Motor Handpiece: DC 2.4V
	Charger: AC 100-240V~, 50/60Hz
Power Consumption	Motor Handpiece: 3VA / Charger: 7VA
Charging Time	180 minutes
Torque Setting Range	10 / 15 / 20 / 25 / 30 N·cm
RPM Setting	15(LOW) / 20(HIGH) RPM

111-ED-040

Protection	Type BF, Battery-powered
Rated Voltage	Motor Handpiece: DC 3.7V
	Charger: AC 100-240V~, 50/60Hz
Power Consumption	Motor Handpiece: 1.85VA / Charger: 12VA
Charging Time	180 minutes
Torque Setting Range	10 / 15 / 20 / 25 / 30 N·cm
RPM Setting	30(LOW) / 40(MID) / 50(HIGH) RPM

Dual Top Anchor System	Maximum Torque Value
Micro Screw (1.4 mm)	15 N·cm
Mid Screw (1.6 mm)	20 N·cm
Mini Screw (2.0 mm)	30 N·cm



Convenient and Easy To Set Up

ORTHONIA has a user friendly designed LCD and push button.

Reverse Function

ORTHONIA has a reverse rotation function that is very useful to remove implants.

Speed Level(RPM)

111-ED-010: LOW / HIGH
111-ED-040: LOW / MID / HIGH

Accurate Torque Limit

ORTHONIA has five levels of torque limits at every 5 N·cm between 10N·cm and 30N·cm to protect the screw from fracturing.



111-ED-010



111-ED-040

Code	Speed level (RPM)	Torque
111-ED-010	15 (LOW) / 20 (HIGH)	10 / 15 / 20 / 25 / 30 N·cm
111-ED-040	30 (LOW) / 40 (MID) / 50 (HIGH)	10 / 15 / 20 / 25 / 30 N·cm

Lingual Driver

Dentists can approach all intraoral areas by revolutionary 360° rotating hand piece



Code	Description
111-LD-020	Lingual Driver

Finger Driver

Finger Driver is designed for an easy implantation of the Dual Top® Screws at lingual or palatal area



Code	Description
111-120	Finger Driver

JEILMEDICAL

JEILMEDICAL CORPORATION

804-ho, 55, Digital-ro 34-gil, Guro-gu, Seoul, 08378, Republic of Korea

DOMESTIC SALES **T** 82.2.850.3500 **F** 82.2.850.3535 **E** marketing@jeilmed.co.kr

INTERNATIONAL SALES **T** 82.2.850.3304 **F** 82.2.850.3537 **E** global@jeilmed.co.kr

www.jeilmed.co.kr

Print Date: 2025-01-14 02-A01(03)