

Invisacta

CONCEALED HINGES



Since **1956**, thanks to our hinges, more than **1,000,000,000**
doors are opening **in 80 countries** all over the world.



COMPANY

OTLAV S.p.A produces and sells hinges for doors and windows and other accessories for frames.

Founded in 1956 by entrepreneur Angelo Padovan, Otlav has produced **more than 2,2 billion of hinges**.

Thanks to almost 100 filed patents, Otlav ensures high quality standards and is present with its wide range of products in more than **80 countries worldwide**. OTLAV new factory was inaugurated in 2007, in Via Angelo Padovan 2 in Santa Lucia di Piave (TV), in an area of 45,000 square meters, 19,500 of which are covered.

Following the opening of the first office in March 1956, OTLAV has nowadays found its perfect location to face the challenges of the new millennium. "OAMH" "Otlav Automatic Material Handling" is a project developed after five years of research and studies all around the world; a technological jewel created by designing at first the best logistical location, and then a subsequent lay out, and eventually the container to cover these structures: an unmistakable technological masterpiece, which is 20 meters high.

Rationalization of space, optimization of logistics and integrated use of automation: all of these account for respectively the flow or transportation of materials and the streaming of information. The goal is to cut costs by making the produced hinges increasingly competitive with an unparalleled level of quality.

OTLAV group companies



In 1990 Otlav creates Myrtus in Maniago (PN), Friuli. The company is specialized in galvanic treatments.



Founded 2002 in Romania is focused on some high-tech producing processes.



As required by European regulations and by Regulation (EU) No. 305/2011 all OTLAV hinges are subjected to stringent resistance tests to check performance both during the design phase and regularly during manufacturing. The I.U.S. (Intensive Use Simulator) is the testing system used in the OTLAV Test Laboratories.

EC Certificates and Performance Declarations

Tests on the hinges are also carried out at external bodies able to certify that the company manufactures according to rigid, systematically monitored production plans and that the products pass the tests envisaged by the standard UNI EN 1935/2004: they are thereby able to issue, if needed, the CE certificate or certify the data provided by OTLAV in the "performance declarations".



View of the OTLAV test laboratories I.U.S. (Intensive Use Simulator)

INVISACTA PLUS+

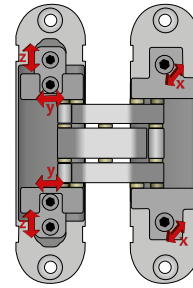
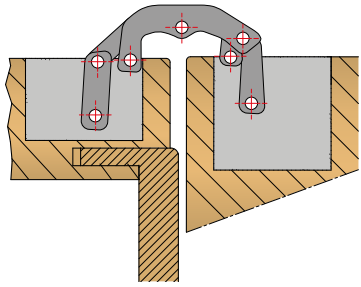

7 JUNCTION FULCRUMS

No sliding wear

7 fulcrum points allow little friction, good flow, solidity and high loading capacity; no contact between the different bearing units thanks to nylon bushes with high friction resistance.

3 ADJUSTMENTS

With only one hex spanner

The clamping screws, placed in the outer casings, are not used for hinge adjustment, therefore they remain stable for a long time.

IN570, IN310, IN303, IN300, IN305, IN230 and IN235 models

COMPATIBILITY

Same milling, different hinges

IN230

Doors up to 60 kg



IN235

Doors up to 40 kg



AI230

Door alignment device



Milling 23x120 mmh

IN303

Doors up to 80 kg



IN300

Doors up to 60 kg



IN305

Doors up to 40 kg



IN299

Doors up to 40 kg



CI335

Doors up to 40 kg



AI300

Door alignment device



Milling 30x120 mmh

INVISACTA PLUS+

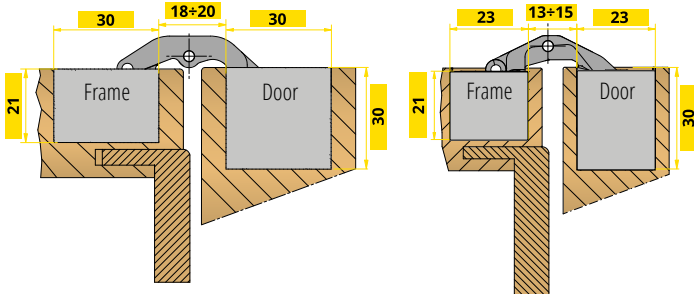

MINIMAL DIMENSIONS

Slot on frame side: 21 mm

A 21 mm depth slot on the frame side makes it unique and enables its perfect integration in reduced spaces. No need to cut the architrave which can be flush mounted.

IN303, IN300, IN305, IN301, IN299, IN230 and IN235 models

REVERSIBILITY

Invisacta hinges are all reversible

The hinge if mounted in the center of the door thickness*, allows the reversibility of the door, thus enabling the **optimization of the stock and logistics at installation.**

* IN570, IN303, IN300, IN305, IN301 and IN299 models

KIND OF FINISHING

The wide range of colours allows finding the right correspondence with any finish of the doors



White Matt

Chrome Plated

Satinized Silver

Zinc Plated

Satinized Nickel

Dark Titanium

Matt Black



Polished Gold

Matt Gold

Light Bronze

Brushed Bronze

Bronze Powder Coated

Bronze Plated

IN311 3D concealed hinge for heavy doors

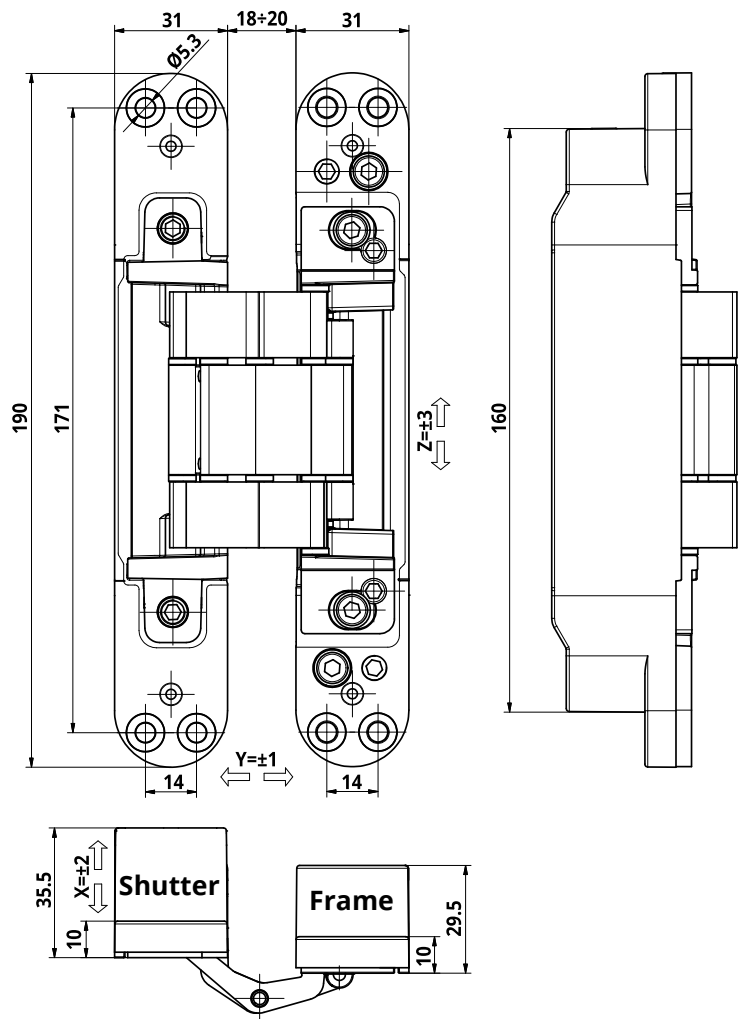

Technical data

Capacity*	140 Kg
Hinge height	190 mm
Width shutter side	31 mm
Width frame side	31 mm
Depth shutter side	35,5 mm
Depth frame side	29,5 mm
Door opening angle	180°

Side adjustment	± 2 mm
Height adjustment	± 3 mm
Depth adjustment	± 1 mm

* Tested with 90x210 cm doors - For more information on the number of hinges to be used according to the weight and dimension of the door, please see the loading charts available on the website www.otlav.it.

Technical features

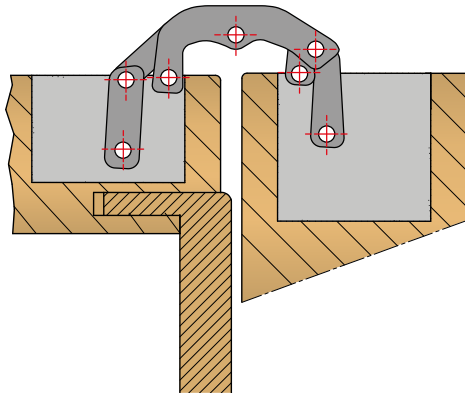

- Movement on **7 junction fulcrums** equipped with bearing in plastic HT with high resistance and long life.
- Equipped with **3-way progressive adjustments** that can be settled by means of just one 4 mm hex-spanner. Once installed, the door has natural sinking, Invisacta hinge allows to set the door back to the start position.
- The height adjustment is equipped with a safety device that prevents the door from accidentally sliding.
- **The hinge can be fitted with door closing devices.**
- Outer casings protect the inner junction fulcrums against rubble coming from door installation works.
- The clamping screws, placed in the outer casings, are not used for hinge adjustment, therefore they remain stable for a long time.
- **CE certified** - according European Assessment Document 020001-01-0405.
- The hinge meets the **anti-burglary** criteria according European Assessment Document 020001-01-0405.
- **Fireproof certified 90'** according UNI-EN 1634-1.
- Reversible
- Material of levers: aluminium.
- Material of casing: zamak.
- **Caps** available to conceal the screws.

Finishing



IN311190V703
Satinized Silver Plated



IN311190VN03
Satinized Nickel Plated



IN3111909N03
Matt Black



IN3111909P03
White Matt RAL 9016

**OTHER KIND OF FINISHING
AVAILABLE ON REQUEST**

IN310 3D concealed hinge for heavy doors

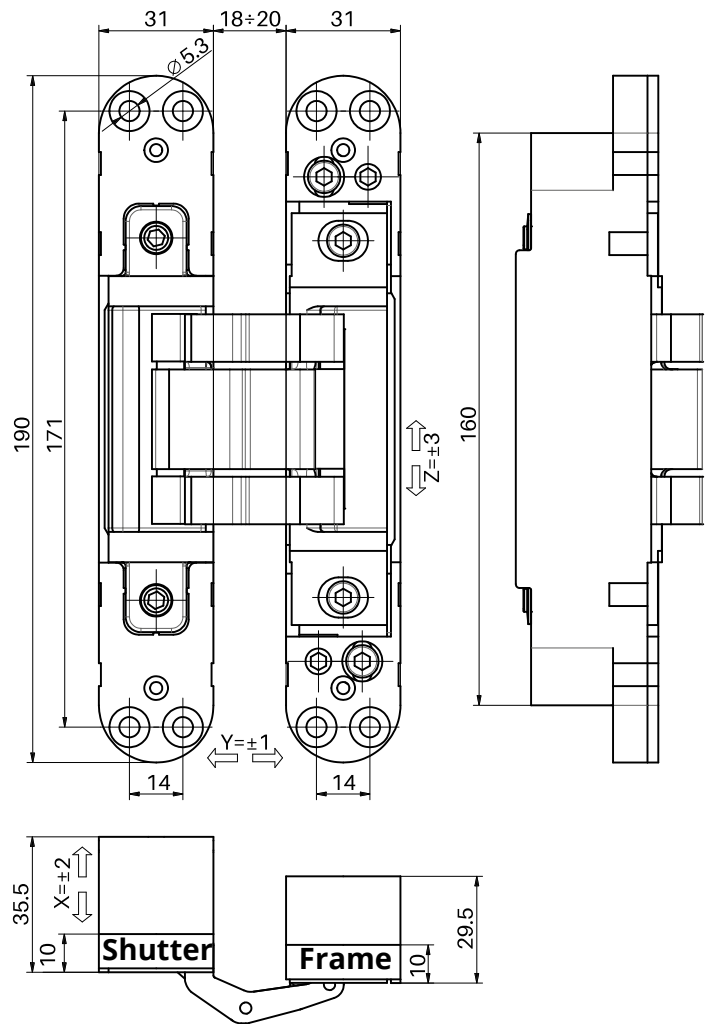

Technical data

Capacity*	120 Kg
Hinge height	190 mm
Width shutter side	31 mm
Width frame side	31 mm
Depth shutter side	35,5 mm
Depth frame side	29,5 mm
Door opening angle	180°

Side adjustment	± 2 mm
Height adjustment	± 3 mm
Depth adjustment	± 1 mm

* Tested with 90x210 cm doors - For more information on the number of hinges to be used according to the weight and dimension of the door, please see the loading charts available on the website www.otlav.it.

Technical features

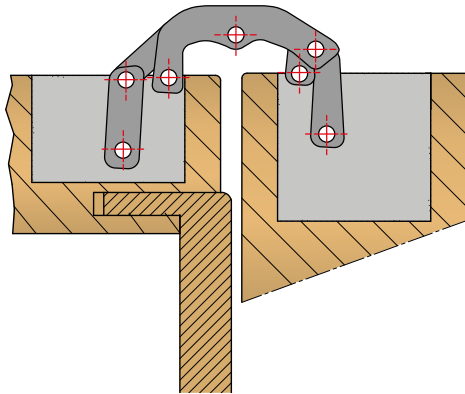

- Movement on **7 junction fulcrums** equipped with bearing in plastic HT with high resistance and long life.
- Equipped with **3-way adjustments** that can be settled by means of just one 4 mm hex-spanner. Once installed, the door has natural sinking, Invisacta hinge allows to set the door back to the start position.
- The height adjustment is equipped with a safety device that prevents the door from accidentally sliding.
- **The hinge can be fitted with door closing devices.**
- Outer casings protect the inner junction fulcrums against rubble coming from door installation works.
- The clamping screws, placed in the outer casings, are not used for hinge adjustment, therefore they remain stable for a long time.
- **CE certified** - according European Assessment Document 020001-01-0405.
- The hinge meets the **anti-burglary** criteria according European Assessment Document 020001-01-0405.
- **UL certified - Fireproof 90'** - standard UL 10C.
- **Fireproof certified 90'** according UNI-EN 1634-1.
- Reversible
- Material of levers: aluminum.
- Material of casing: zamak.
- **Caps** available to conceal the screws.

Finishing



IN310190V703
Satinized Silver Plated



IN310190VN03
Satinized Nickel Plated



IN3101909N03
Matt Black



IN3101909P03
White Matt RAL 9016



IN310190VD03
Polished Chrome



IN310190VO03
Polished Gold



IN310190VS03
Brushed Bronze

**OTHER KIND OF FINISHING
AVAILABLE ON REQUEST**

IN570 3D offset concealed hinge for 60 Kg doors

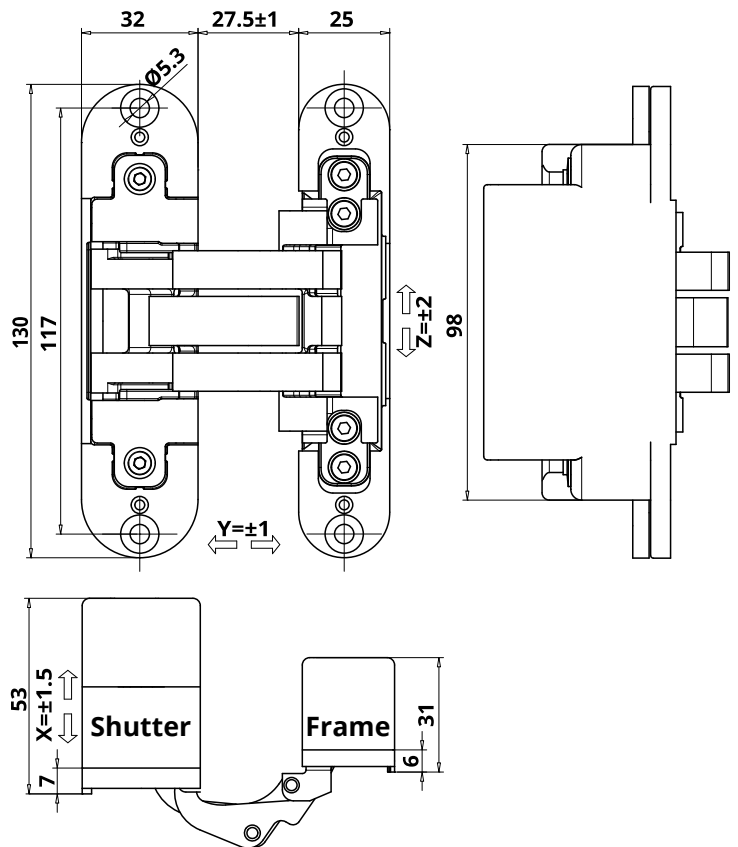

Technical data

Capacity*	60 Kg
Hinge height	130 mm
Width shutter side	32 mm
Width frame side	25 mm
Depth shutter side	53 mm
Depth frame side	31 mm
Door opening angle	180°
Side adjustment	± 1.5 mm
Height adjustment	± 2 mm
Depth adjustment	± 1 mm

* Tested with 90x210 cm doors - For more information on the number of hinges to be used according to the weight and dimension of the door, please see the loading charts available on the website www.otlav.it.

Technical features

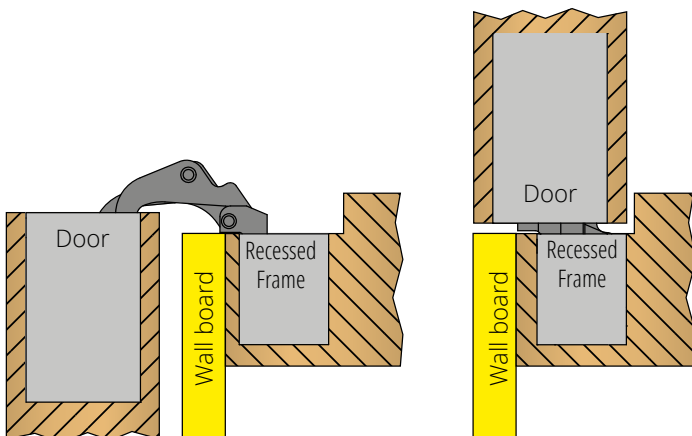

- The hinge is suitable to be installed on doors with **recessed frame** to accept application of wall board to match the door.
- Suitable for installation on panels with **thickness from 40 to 60 mm**. For larger thickness please contact OTLAV technical department.
- The hinge is reversible, it **can be mounted in the center of the door thickness with 40 and 44 mm panels**, allowing the **reversibility of the door**, thus enabling the optimization of the stock and logistics at installation.
- The hinge can be installed with mounted gasket up to 6 mm thick.
- Allows the application of very thick architraves or coating panels: up to 18 mm.
- Material of casing: zamak.
- Material of levers: aluminium.
- Movement on **7 junction fulcrums** equipped with bearing in plastic HT with high resistance and long life.
- Equipped with **3-way adjustments** that can be settled by means of just one hex-spanner. Once installed, the door has natural sinking, Invisacta hinge allows to set the door back to the start position.
- Outer casings protect the inner junction fulcrums against rubble coming from door installation works.
- The clamping screws, placed in the outer casings, are not used for hinge adjustment, therefore they remain stable for a long time.
- Equipped with **caps** to conceal the screws.

Finishing



IN570130V703
Satinized Silver Plated



IN570130VN03
Satinized Nickel Plated



IN5701309N03
Matt Black



IN570130VM03
Matt Gold

**OTHER KIND OF FINISHING
AVAILABLE ON REQUEST**

IN303 3D concealed hinge for 80 Kg doors

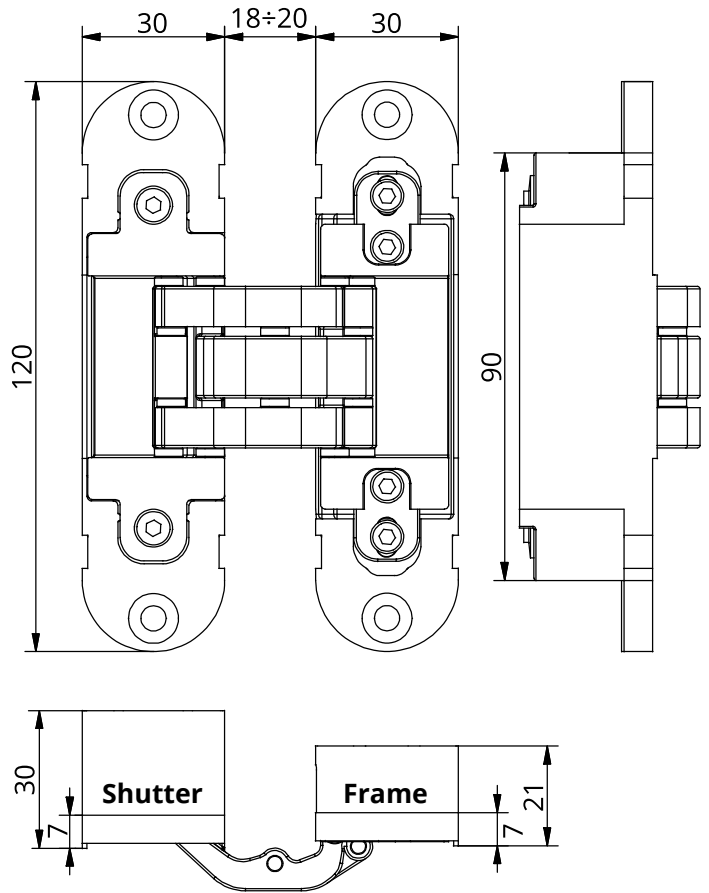

Technical data

Capacity*	80 Kg
Hinge height	120 mm
Width shutter side	30 mm
Width frame side	30 mm
Depth shutter side	30 mm
Depth frame side	21 mm
Door opening angle	180°
Side adjustment	± 1 mm
Height adjustment	± 2 mm
Depth adjustment	± 1 mm

* Tested with 90x210 cm doors - For more information on the number of hinges to be used according to the weight and dimension of the door, please see the loading charts available on the website www.otlav.it.

PATENTED

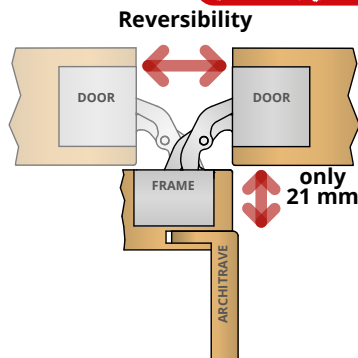

IN303 hinge allows at the same time:
Reversibility of the door with hinge mounted in the center of the door thickness.

No need to cut the architrave thanks to only 21 mm of frame slot depth.

Patented EP-B2719851.

Technical features

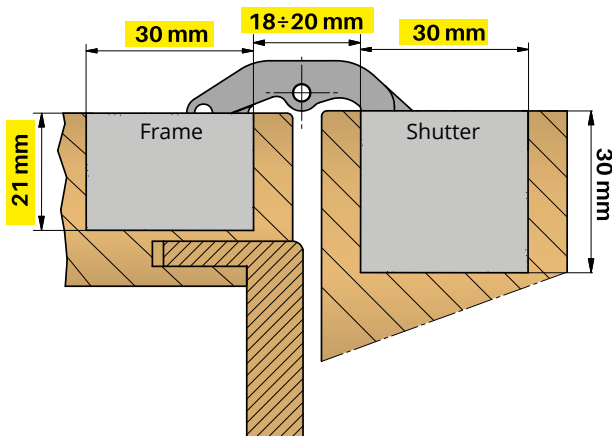

- A 21 mm depth slot on the frame side makes it unique and enables its **perfect integration in reduced spaces**. No need to cut the architrave which can be flush mounted.
- The hinge is reversible, if mounted in the center of the door thickness, allows the **reversibility of the door**, thus enabling the optimization of the stock and logistics at installation.
- Movement on **7 junction fulcrums** equipped with bearing in plastic HT with high resistance and long life.
- Equipped with **3-way adjustments** that can be settled by means of just one 3 mm hex-spanner. Once installed, the door has natural sinking, Invisacta hinge allows to set the door back to the start position.
- During the installation it is possible to **unlock the height adjustment** of the frame part, creating a 4 mm gap, which makes it **easier to insert the hinge** in the slots of the jamb. This is particularly useful in the event that the frame milling are not perfectly aligned with those of the door.
- Outer casings protect the inner junction fulcrums against rubble coming from door installation works.
- The clamping screws, placed in the outer casings, are not used for hinge adjustment, therefore they remain stable for a long time.
- **The hinge can be fitted with door closing devices.**
- Material of levers: aluminum.
- Material of casing: zamak.
- **CE certified** - according European Assessment Document 020001-01-0405.
- **Fireproof certified 45'** according UNI-EN 1634-1.
- **UL certified - Fireproof 90'** - standard UL 10C.
- **Aluminium caps** available to conceal the screws.
- IN303, IN300, IN305 and IN299 models **use the same milling**.

Finishing



Hinge **IN303120V702**
Caps **GC300010J102**
Satinized Silver Plated



Hinge **IN303120VN02**
Caps **GC300010J205**
Satinized Nickel Plated

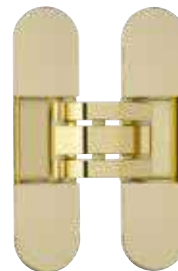

Hinge **IN303120VO02**
Caps **GC300010JO05**
Polished Gold



Hinge **IN3031209N02**
Caps **GC3000109N02**
Matt Black



Hinge **IN3031209P02**
Caps **GC3000109P02**
White Matt RAL 9016



Hinge **IN303120VS02**
Caps **GC300010VS02**
Brushed Bronze

**OTHER KIND OF FINISHING
AVAILABLE ON REQUEST**

IN300 3D concealed hinge for 60 Kg doors

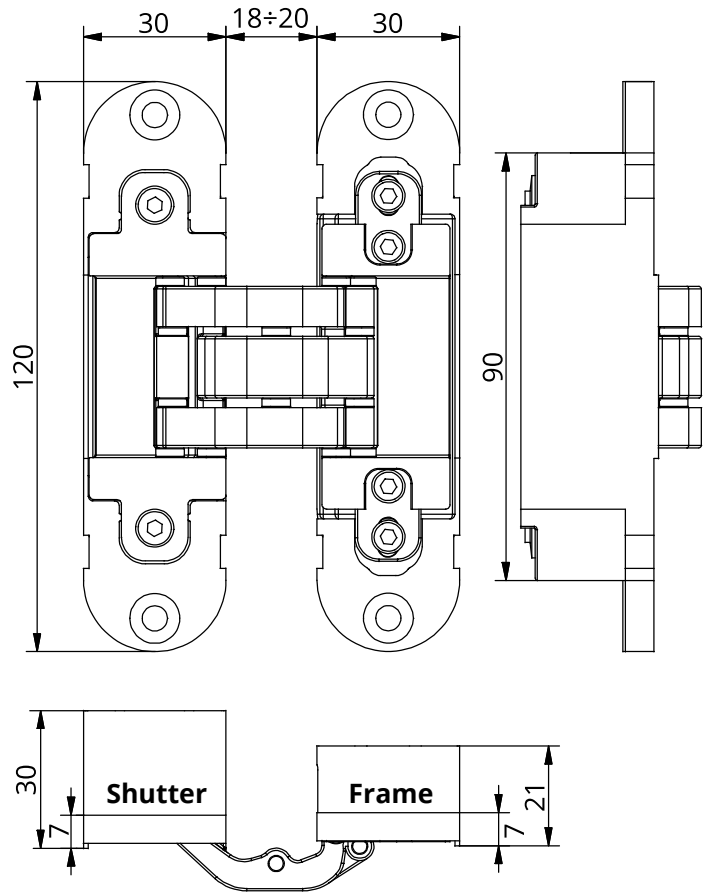

Technical data

Capacity*	60 Kg
Hinge height	120 mm
Width shutter side	30 mm
Width frame side	30 mm
Depth shutter side	30 mm
Depth frame side	21 mm
Door opening angle	180°
Side adjustment	± 1 mm
Height adjustment	± 2 mm
Depth adjustment	± 1 mm

* Tested with 90x210 cm doors - For more information on the number of hinges to be used according to the weight and dimension of the door, please see the loading charts available on the website www.otlav.it.

PATENTED

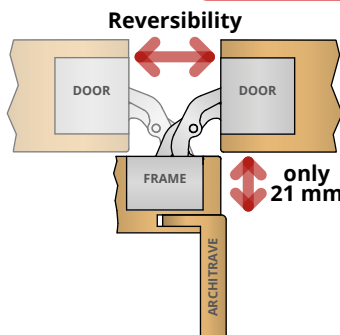

IN300 hinge allows at the same time:

Reversibility of the door with hinge mounted in the center of the door thickness.

No need to cut the architrave thanks to only 21 mm of frame slot depth. Patented EP-B2719851.

Technical features

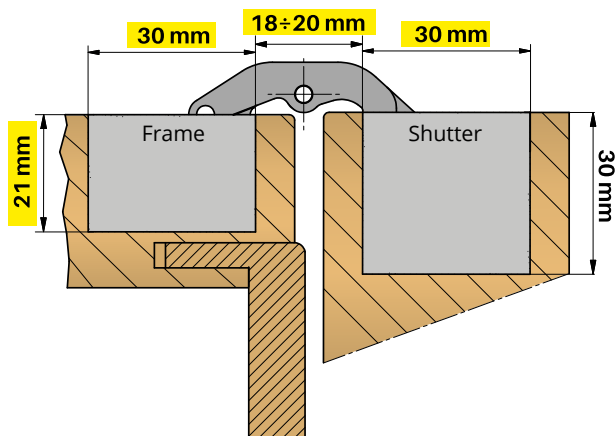

- A 21 mm depth slot on the frame side makes it unique and enables its **perfect integration in reduced spaces**. No need to cut the architrave which can be flush mounted.
- The hinge is reversible, if mounted in the center of the door thickness, allows the **reversibility of the door**, thus enabling the optimization of the stock and logistics at installation.
- Movement on **7 junction fulcrums** equipped with bearing in plastic HT with high resistance and long life.
- Equipped with **3-way adjustments** that can be settled by means of just one 3 mm hex-spanner. Once installed, the door has natural sinking, Invisacta hinge allows to set the door back to the start position.
- During the installation it is possible to **unlock the height adjustment** of the frame part, creating a 4 mm gap, which makes it **easier to insert the hinge** in the slots of the jamb. This is particularly useful in the event that the frame milling are not perfectly aligned with those of the door.
- Material of hinge: zamak.
- **The hinge can be fitted with door closing devices.**
- Outer casings protect the inner junction fulcrums against rubble coming from door installation works.
- The clamping screws, placed in the outer casings, are not used for hinge adjustment, therefore they remain stable for a long time.
- Material of hinge: Zamak.
- **CE certified** - according European Assessment Document 020001-01-0405
- **Fireproof certified 30'** according UNI-EN 1634-2.
- **Aluminium caps** available to conceal the screws.
- IN303, IN300, IN305 and IN299 models **use the same milling.**

Finishing



Hinge **IN300120V702**
Caps **GC300010J102**
Satinized Silver Plated



Hinge **IN300120VN02**
Caps **GC300010J205**
Satinized Nickel Plated



Hinge **IN3001209P02**
Caps **GC3000109P02**
White Matt RAL 9016



Hinge **IN300120H004**
Caps **GC300010J102**
Zinc Plated



Hinge **IN300120B002**
Caps **GC3000109R02**
Bronze Plated

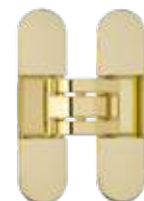

Hinge **IN300120V002**
Caps **GC300010J005**
Polished Gold



Hinge **IN3001209N02**
Caps **GC3000109N02**
Matt Black



Hinge **IN300120VM02**
Caps **GC300010VM02**
Matt Gold



Hinge **IN300120VS02**
Caps **GC300010VS02**
Brushed bronze



Hinge **IN300120VU02**
Caps **GC300010VU02**
Light Bronze



Hinge **IN300120NE02**
Caps **GC300010NE02**
Dark Titanium

IN305 3D concealed hinge for 40 Kg doors

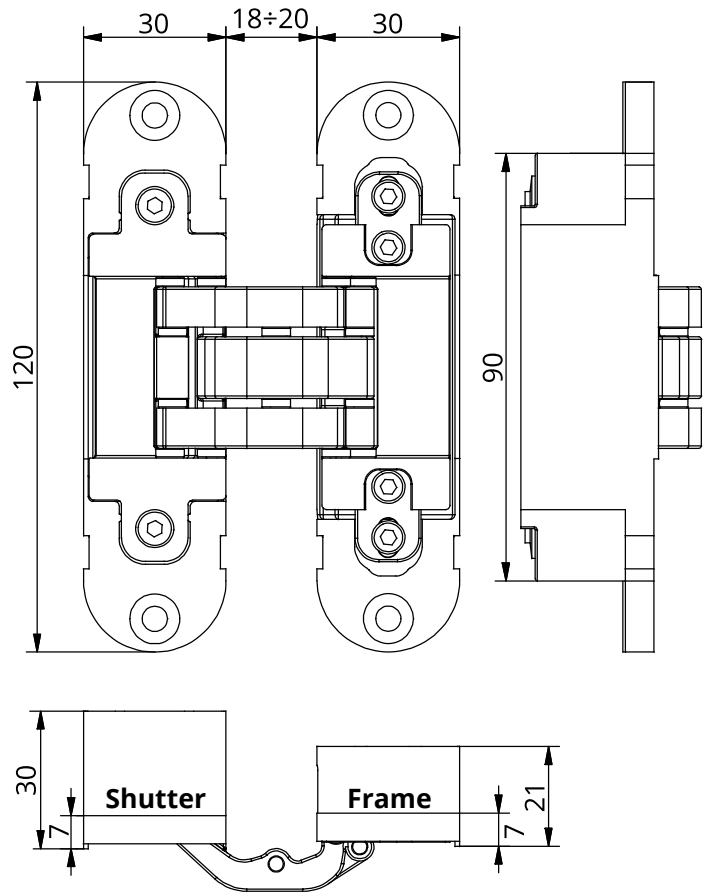

Technical data

Capacity*	40 Kg
Hinge height	120 mm
Width shutter side	30 mm
Width frame side	30 mm
Depth shutter side	30 mm
Depth frame side	21 mm
Door opening angle	180°
Side adjustment	± 1 mm
Height adjustment	± 2 mm
Depth adjustment	± 1 mm

* Tested with 90x210 cm doors - For more information on the number of hinges to be used according to the weight and dimension of the door, please see the loading charts available on the website www.otlav.it.

PATENTED

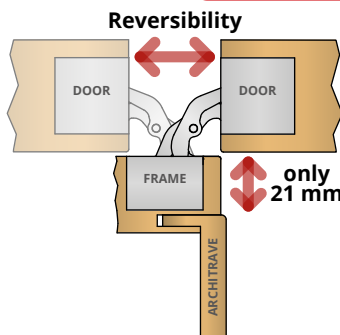

IN305 hinge allows at the same time:

Reversibility of the door with hinge mounted in the center of the door thickness.

No need to cut the architrave thanks to only 21 mm of frame slot depth. Patented EP-B2719851.

Technical features

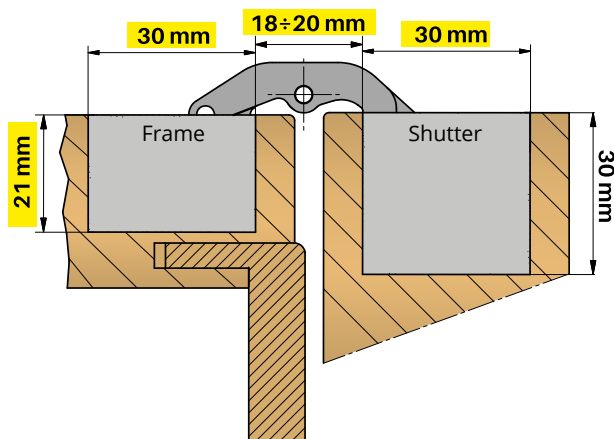

- A 21 mm depth slot on the frame side makes it unique and enables its **perfect integration in reduced spaces**. No need to cut the architrave which can be flush mounted.
- The hinge is reversible, if mounted in the center of the door thickness, allows the **reversibility of the door**, thus enabling the optimization of the stock and logistics at installation.
- Movement on **7 junction fulcrums** equipped with bearing in plastic HT with high resistance and long life.
- Equipped with **3-way adjustments** that can be settled by means of just one 3 mm hex-spanner. Once installed, the door has natural sinking, Invisacta hinge allows to set the door back to the start position.
- During the installation it is possible to **unlock the height adjustment** of the frame part, creating a 4 mm gap, which makes it **easier to insert the hinge** in the slots of the jamb. This is particularly useful in the event that the frame milling are not perfectly aligned with those of the door.
- Material of hinge: Zamak.
- Material of casing: thermoplastic polymer.
- Outer casings protect the inner junction fulcrums against rubble coming from door installation works.
- The clamping screws, placed in the outer casings, are not used for hinge adjustment, therefore they remain stable for a long time.
- **Aluminium caps** available to conceal the screws.
- IN303, IN300, IN305 and IN299 models **use the same milling**.

Finishing



IN305120V705
Satinized Silver Plated



IN3051209P04
White Matt RAL 9016



IN3051209N04
Matt Black Plastified

**OTHER KIND OF FINISHING
AVAILABLE ON REQUEST**

IN230 3D concealed hinge for 60 Kg doors

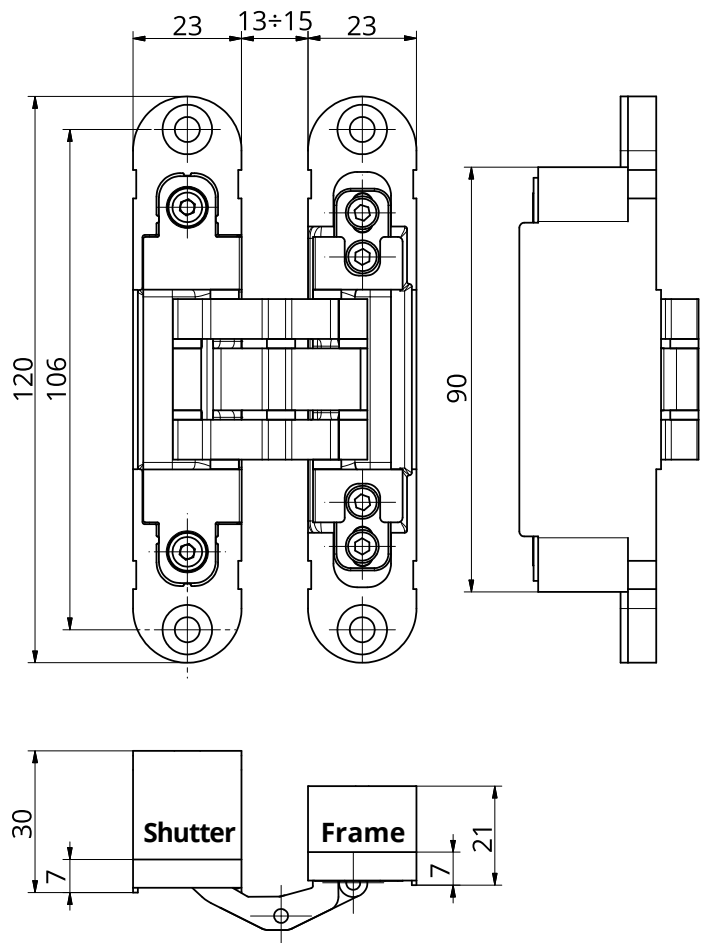

Technical data

Capacity*	60 Kg
Hinge height	120 mm
Width shutter side	23 mm
Width frame side	23 mm
Depth shutter side	30 mm
Depth frame side	21 mm
Door opening angle	180°
Side adjustment	± 1 mm
Height adjustment	± 2 mm
Depth adjustment	± 1 mm

* Tested with 90x210 cm doors - For more information on the number of hinges to be used according to the weight and dimension of the door, please see the loading charts available on the website www.otlav.it.

Technical features

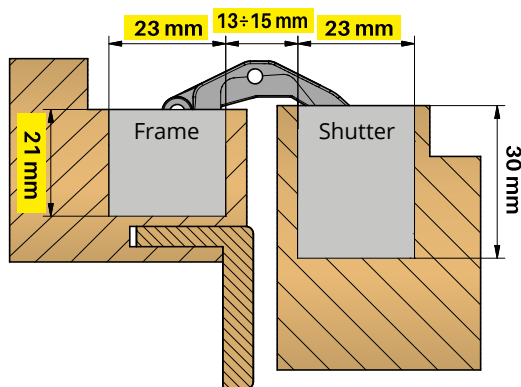

- A **21 mm depth slot** on the frame side makes it unique and enables its perfect integration in reduced spaces. No need to cut the architrave which can be flush mounted.
- Movement on **7 junction fulcrums** equipped with bearing in plastic HT with high resistance and long life.
- Equipped with **3-way adjustments** that can be settled by means of just one 3 mm hex-spanner. Once installed, the door has natural sinking, Invisacta hinge allows to set the door back to the start position.
- During the installation it is possible to **unlock the height adjustment** of the frame part, creating a 4 mm gap, which makes it **easier to insert the hinge** in the slots of the jamb. This is particularly useful in the event that the frame milling are not perfectly aligned with those of the door.
- The hinge is reversible.
- **The hinge can be fitted with door closing devices.**
- Outer casings protect the inner junction fulcrums against rubble coming from door installation works.
- The clamping screws, placed in the outer casings, are not used for hinge adjustment, therefore they remain stable for a long time.
- Material of hinge: Zamak.
- **CE certified** - according European Assessment Document 020001-01-0405
- **Fireproof certified 30'** according UNI-EN 1634-2
- **Aluminium caps** available to conceal the screws.

**OTHER KIND OF FINISHING
AVAILABLE ON REQUEST**

Finishing



Hinge **IN230120V702**
Caps **GC230010J102**
Satinized Silver Plated



Hinge **IN230120VN02**
Caps **GC230010J202**
Satinized Nickel Plated

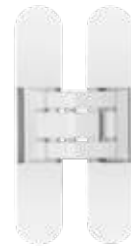

Hinge **IN2301209P02**
Caps **GC2300109P02**
White Matt RAL 9016



Hinge **IN2301209N02**
Caps **GC2300109N02**
Matt Black



Hinge **IN230120V002**
Caps **GC230010JO05**
Polished Gold



Hinge **IN230120VM02**
Caps **GC230010VM02**
Matt Gold



Hinge **IN230120VD02**
Caps **GC230010JD02**
Chrome Plated



Hinge **IN230120NE02**
Caps **GC230010NE02**
Dark Titanium



Hinge **IN230120BO02**
Caps **GC2300109R02**
Bronze Plated



Hinge **IN230120VU02**
Caps **GC230010VU02**
Light Bronze

IN235 3D concealed hinge for 40 Kg doors

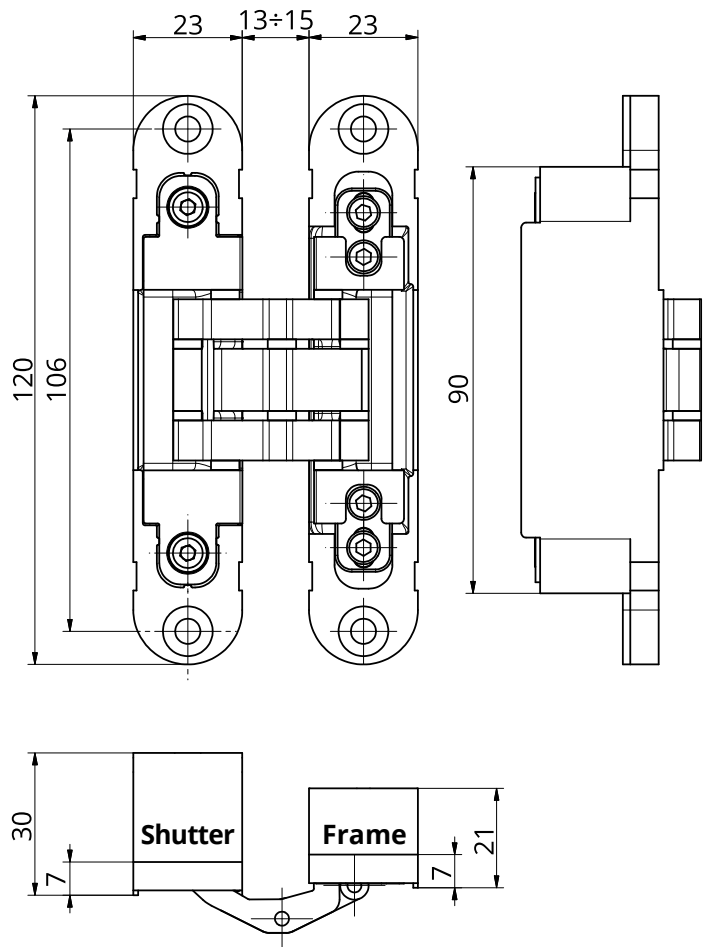

Technical data

Capacity*	40 Kg
Hinge height	120 mm
Width shutter side	23 mm
Width frame side	23 mm
Depth shutter side	30 mm
Depth frame side	21 mm
Door opening angle	180°
Side adjustment	± 1 mm
Height adjustment	± 2 mm
Depth adjustment	± 1 mm

* Tested with 90x210 cm doors - For more information on the number of hinges to be used according to the weight and dimension of the door, please see the loading charts available on the website www.otlav.it.

Technical features

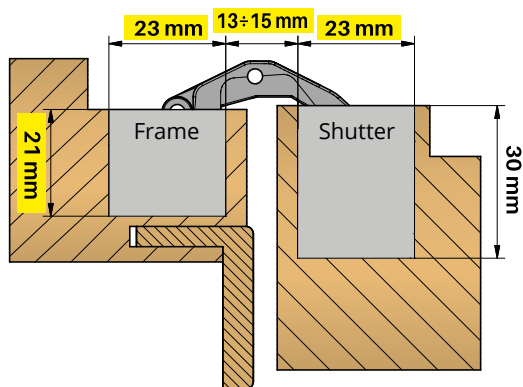

- A **21 mm depth slot** on the frame side makes it unique and enables its perfect integration in reduced spaces. No need to cut the architrave which can be flush mounted.
- Movement on **7 junction fulcrums** equipped with bearing in plastic HT with high resistance and long life.
- Equipped with **3-way adjustments** that can be settled by means of just one 3 mm hex-spanner. Once installed, the door has natural sinking, Invisacta hinge allows to set the door back to the start position.
- During the installation it is possible to **unlock the height adjustment** of the frame part, creating a 4 mm gap, which makes it **easier to insert the hinge** in the slots of the jamb. This is particularly useful in the event that the frame milling are not perfectly aligned with those of the door.
- Material of hinge: Zamak.
- Material of casing: thermoplastic polymer.
- The hinge is reversible.
- Outer casings protect the inner junction fulcrums against rubble coming from door installation works.
- The clamping screws, placed in the outer casings, are not used for hinge adjustment, therefore they remain stable for a long time.
- **Aluminium caps** available to conceal the screws.

Finishing



IN235120V708
Satinized Silver Plated



IN235120H008
Zinc Plated



IN2351209P17
White Matt RAL 9016



IN235120VN08
Satinized Nickel Plated

**OTHER KIND OF FINISHING
AVAILABLE ON REQUEST**

CI335150N035 Plate hinge for 40 Kg doors

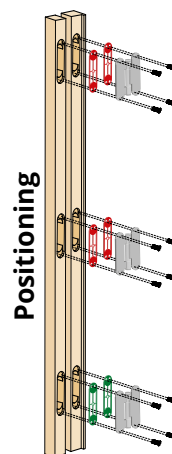
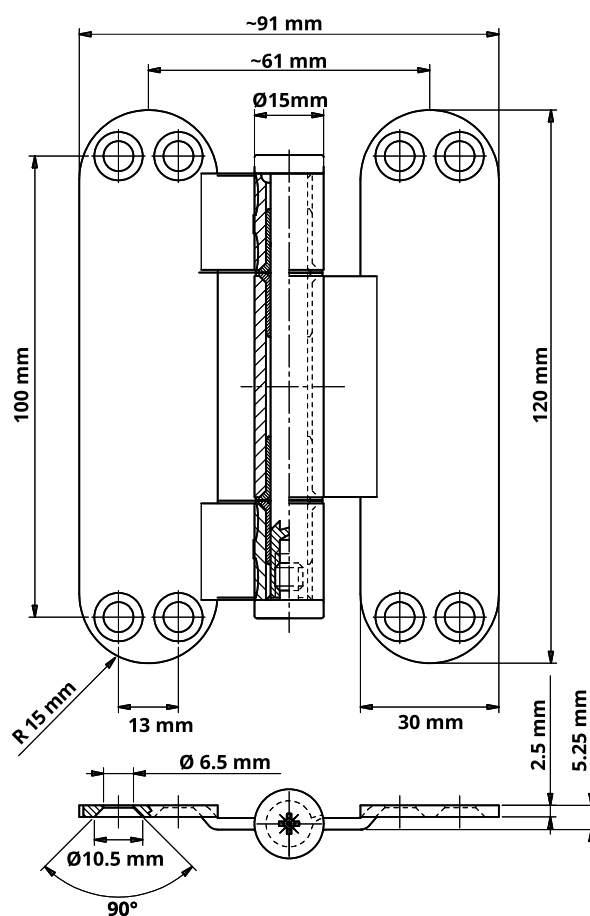

Technical features

- The hinge is suitable to be installed on doors and frames with IN299, IN300, IN303 and IN305 milling.
- The hinge can be fitted right and left.
- Equipped with spacers that allows to prevent the natural sinking of the door.
- Kit composed by: 3 hinges, 4 green spacer, 4 red spacer and 24 screws

Technical data

Capacity* 40 Kg

* Tested with 90x210 cm doors - For more information on the number of hinges to be used according to the weight and dimension of the door, please see the loading charts available on the website www.otlav.it.

Finishing

Nickel plated

Accessories

Adjustable door alignment device

- The device allows to keep the shutter aligned to the frame, avoiding in this way door deformities.
- Equipped with adjustable tension of the door jamb.
- Aluminium caps available to conceal the screws.

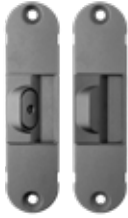

AI300

Compatible with milling of IN300, IN305 and IN303 hinges



AI230

Compatible with milling of IN230 and IN235 hinges

Plate



JC522

Fixing plate for IN310



NP120040H502

Plate for IN299, IN300, IN303 and IN305 hinges

NP120040H504

Plate for IN230 and IN235 hinges



PP02

Shim to set up the plate NP120

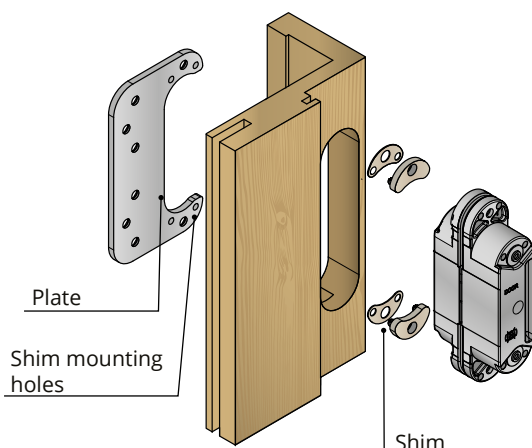

Jigs



MUDIMINVG002

Aluminium holder for template guides



MUMAS230G002

Aluminium guides for IN230 and IN235

MUMAS300G002

Aluminium guides for IN299, IN300, IN303 and IN305

MUMAS310G002

Aluminium guides for IN310



MUBAS500G002

Nylon holder for template guides

MUMAS230W004

Nylon guides for IN230 and IN235

MUMAS300R004

Nylon guides for IN299, IN300, IN303 and IN305

MUMAS310N004

Nylon guides for IN310



Wedge



PP105050Y202

Wedge with 5 spacers

Cap



TP230120Z002

Nylon cap for IN230 and IN235 holes

19/07/24



Via Angelo Padovan, 2
31025 - Santa Lucia di Piave (TV) - Italy
tel. +39 0438 4611
www.otlav.it - info@otlav.it