

**THEEGARTEN**<sup>PAC</sup><sub>TEC</sub>  
smarter packaging

## Packaging

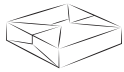

Bottom Fold



Envelope Fold

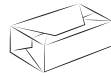

Envelope Fold



Envelope Fold

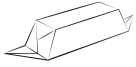

Vienna-Fruit-Fold



Cube



Bunch



Side Twist-Sachet



Side Twist-Basket



Side Twist



Top Twist



Double Twist



Double Twist Rocks



Double Twist



Fringed Wrapping Style



Double Twist



Lollipop



Foil Wrap

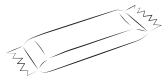

Flow Pack

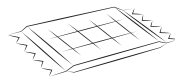

Flow Pack



Flow Pack

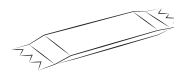

Flow Pack

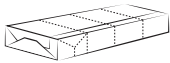

Stick Pack flat

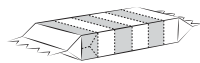

Flow Pack

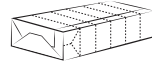

Stick Pack on edge

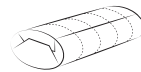

Stick Pack on edge (oval)

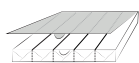

Display Carton

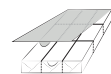

Display Carton

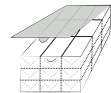

Display Carton



Display Carton

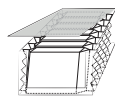

Display Carton

**The name Theegarten-Pactec stands for complex and intelligent solution competence in the working field of packaging technology. This applies to the traditional field of confectionery and also to other food stuffs and the field of non-food.**

As one of the world's leading manufacturers, we invite you to get to know the innovative potency and value added of our range of services. This will consistently help you extend your success on the global markets together with us. Simply contact us. Today, our engineers are already working on tomorrow's packaging solutions.



**CLIMATE NEUTRAL**  
COMPANY  
certified by Fokus Zukunft  
climate neutral via offsetting

**THEEGARTEN**<sup>PAC</sup>  
TEC  
smarter packaging

# Wrapping solutions for hard boiled candies and other preformed products



# EK4 | EK3 | MCH | FPH5 |



Double Twist



Side Twist-Sachet



Side Twist-Basket



Flow Pack



Vienna-Fruit-Fold



# | HCW4 + F3/F4 | HCW4 + FPC5

Wrapping system for hard boiled candies , jelly products, chocolate balls and eggs comprising:

- Circulating feeding and distribution conveyors with integrated buffer function
- Double twist wrapping machines EK4
- Collection and discharge conveyors for wrapped products

Alternatively other twist wrapping machines (EK3, MCH, Milletwist), wrapping machines for side twist and foil wrap (MCH), for stick packs (HCW4+F3/F4) and also for flow packs (FPH5) can be connected to such systems.

The wrapping capacities given in the individual machine specification are to be understood as maximum capacities. They may vary depending on the product size, the product consistency and the quality of the wrapping material.

Size ranges given are the standard size ranges of the equipment. Product sizes outside the standard size range remain subject to request.

For more detailed information please ask for specific brochures.



# EK4



## Output

- up to 2300 products/min

## Size Range

Length: 16–40 mm

Width: 12–25 mm

Height: 6–20 mm

disc shaped products:

Height: 6–20 mm

Ø: 13–28 mm

(special design

up to Ø 33 mm)

ball shaped products:

Ø: 17–23 mm

(special design

up to Ø 28 mm)



# EK3



## Output

- up to 1800 products/min

## Size Range

Length: 16–40 mm

Width: 12–25 mm

Height: 6–20 mm

disc shaped products:

Height: 6–20 mm

Ø: 13–28 mm

(special design

up to Ø 33 mm)

ball shaped products:

Ø: 17–23 mm







Double Twist  
Protected Twist



Side Twist-Basket



Side Twist-Sachet

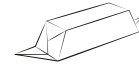

Vienna-Fruit-Fold

# MCH



### Output

- up to 1200 products/min  
Double Twist,  
Protected Twist
- up to 1100 products/min  
Side Twist
- up to 800 products/min  
Vienna-Fruit-Fold

### Size Range

- Length: 16–45 mm
- Width: 12–25 mm
- Height: 6–25 mm
- disc shaped products:  
Height: 6–25 mm
- Ø: 13–33 mm
- ball shaped products:  
Ø: 13–33 mm



Double Twist

# MILLETWIST

### Output

- up to 1000 products/min

### Size Range

- Length: 18–32 mm
- Width: 10–24 mm
- Height: 6–16 mm
- disc shaped products:  
Height: 6–16 mm
- Ø: 18–24 mm
- ball shaped products:  
Ø: 6–16 mm



# HCW4 + FPC5

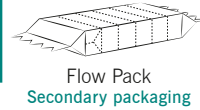

Output  
- up to 1500 single products/min

## Size Range

### HCW4 :

Length: 18– 40 mm

Width: 12– 25 mm

Height: 8– 16 mm

### FPC5:

Length: 44–130 mm

Width: 18– 40 mm

Height: 12– 25 mm

Products per stick pack:  
2 – 16 pieces



# HCW4 + F3/F4



## Leistung

- up to 1500 single products/min

- up to 300 stick packs/min (F3)

- up to 130 stick packs/min (F4)

## Size Range

### HCW4:

Length: 18– 40 mm

Width: 12– 25 mm

Height: 8– 16 mm

### F3/F4

Length: 44–130 mm

Width: 18– 40 mm

Height: 12– 25 mm

Products per stick pack:

2 – 16 pieces





# FPH5

**Output**  
- up to 2000 products/min

**Size Range**  
Length: 15–45 mm  
Width: 12–30 mm  
Height: 5–18 mm  
ball shaped products:  
Ø: 15– 30 mm



Forming, cutting  
and wrapping solutions  
for hard and soft caramels,  
toffees, chewy candies,  
chewing gum and  
bubble gum products

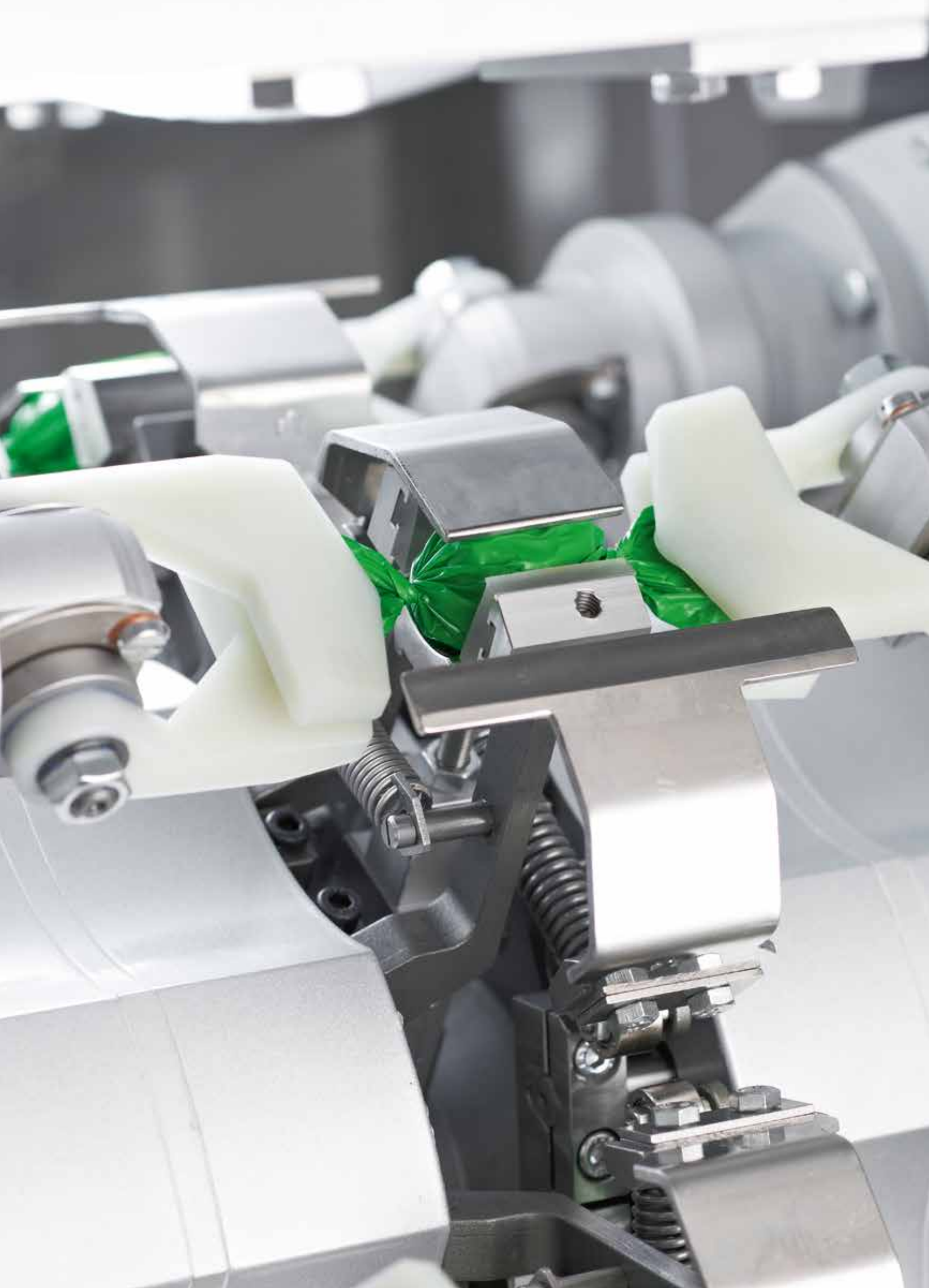

# U1-DCW | WHF2

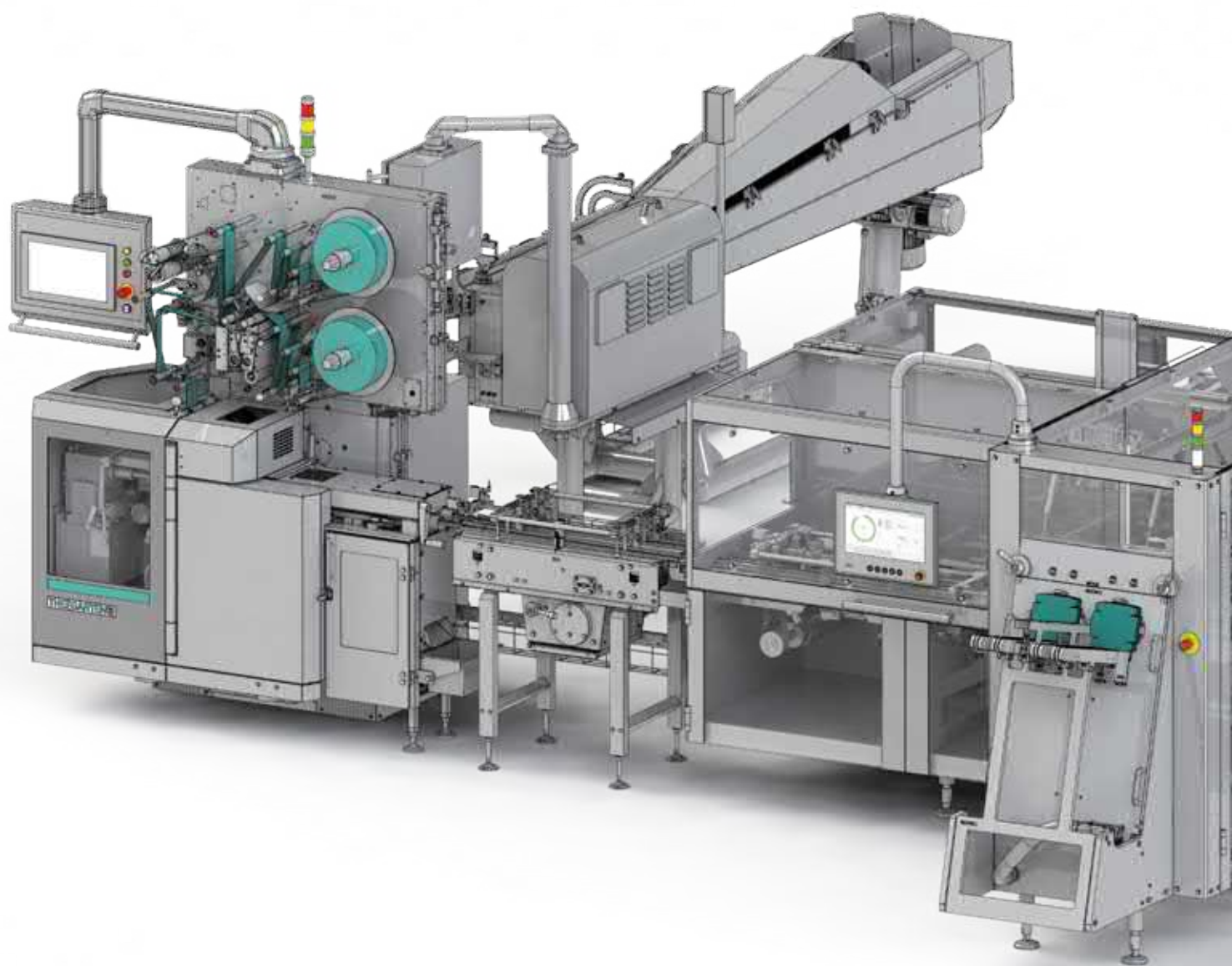
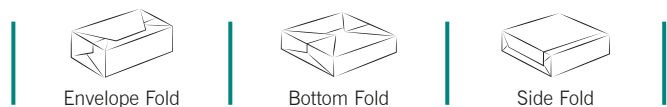

# | BLM

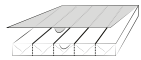

Display Carton  
single-row

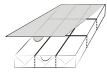

Display Carton  
multi-row

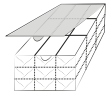

Display Carton  
multi-layer

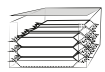

Display Carton  
multi-layer

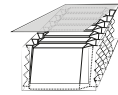

Display Carton  
upright

Cut & wrap system comprising:

- Batch roller and rope sizing machine (alternatively extruder)
- High speed wrapping machine U1-DCW for forming, cutting and packaging of chewing mass
- Cartoning system BLM for secondary packaging of the wrapped products into display cartons (multipacks)

Alternatively other Theegarten-Pactec cut & wrap machines can be connected to such systems.

The wrapping capacities given in the individual machine specification are to be understood as maximum capacities. They may vary depending on the product size, the product consistency and the quality of the wrapping material.

Size ranges given are the standard size ranges of the equipment. Product sizes outside the standard size range remain subject to request.

For more detailed information please ask for specific brochures.

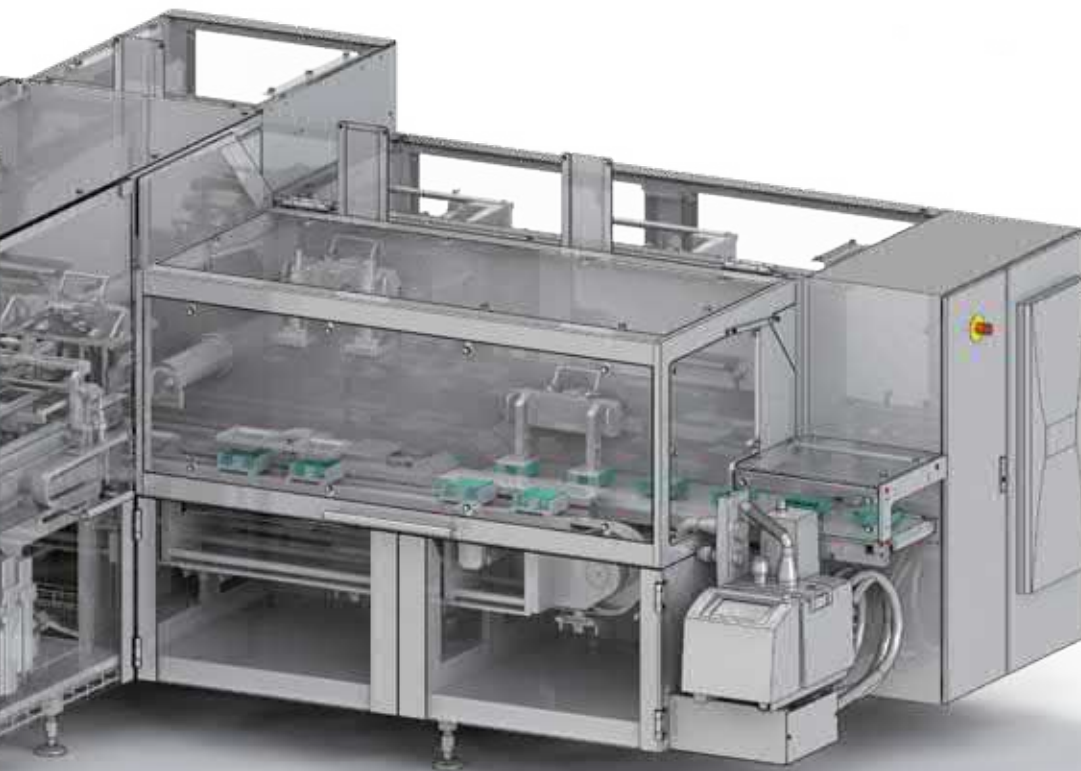

# WHF2



Bottom Fold



Side Fold

## Output

- up to 1800 products/min

## Size Range

Length: 18–40 mm

Width: 12–25 mm

Height: 6–16 mm



# WHD2



Double Twist

## Output

- up to 1800 products/min

## Size Range

Length: 18–40 mm

Width: 12–25 mm

Height: 6–16 mm

Ø: 11–16 mm







Bottom Fold  
Primary packaging

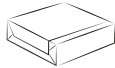

Side Fold  
Primary packaging

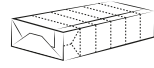

Stick Pack on edge  
Secondary packaging

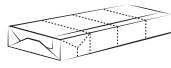

Stick Pack flat  
Secondary packaging

# WHF2 + F3/F4

## Output

- up to 1800 single products/min
- up to 300 stick packs/min (F3)
- up to 130 stick packs/min (F4)

## Size Range

### WHF:

- Length: 18– 40 mm
- Width: 12– 25 mm
- Height: 6– 16 mm

### F3:

- Stick Pack flat
- Length: 44–140 mm
- Width: 18– 40 mm
- Height: 6– 16 mm
- Stick Pack on edge
- Length: 44–140 mm
- Width: 18– 30 mm
- Height: 12– 25 mm

### F4:

- Length: 40–140 mm
- Width: 18– 30 mm
- Height: 12– 25 mm

## Products per stick pack:

### Stick Pack flat:

3 – 8 pieces

### Stick Pack on edge:

3 – 16 pieces

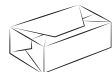
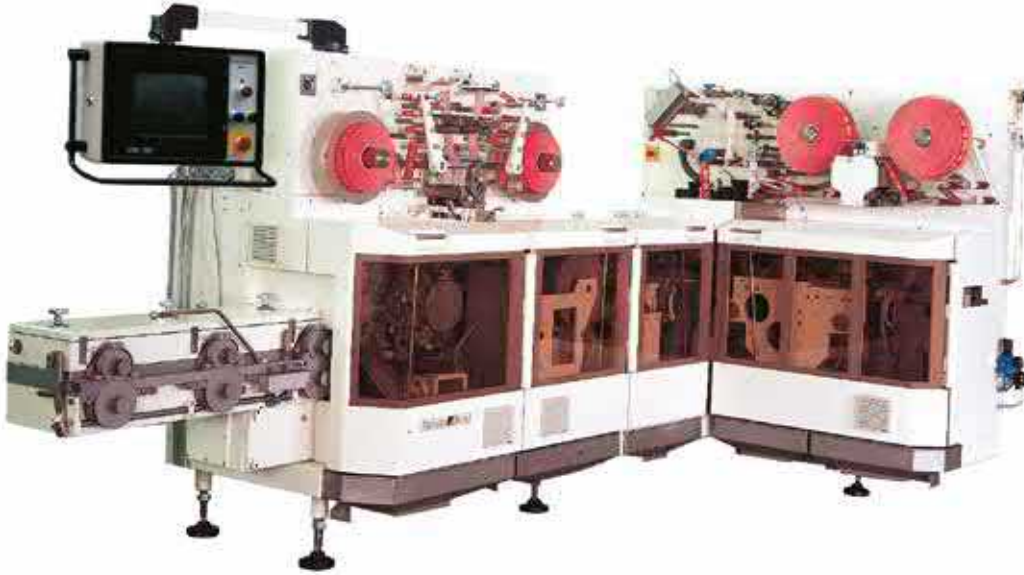

Envelope Fold



Bottom Fold



Side Fold

# U1-DCW

## Output

- up to 2000 products/min

## Size Range

### envelope fold:

- Length: 30–35 mm
- side fold, bottom fold:
- Length: 16–38 mm

Width: 12–25 mm

Height: 4–15 mm

Special sizes upon request



# U1-DCW + F3



## Output

- up to 2000 single products/min
- up to 300 stick packs/min

## Size Range

### U1-DCW

envelope fold:

Length: 30–35 mm

side fold, bottom fold:

Length: 18–38 mm

Width: 12–25 mm

Height: 4–15 mm

Special sizes upon request

### F3:

Stick Pack flat

Length: 44–140 mm

Width: 18–38 mm

Height: 6–15 mm

Stick Pack on edge

Length: 44–140 mm

Width: 18–30 mm

Height: 12–25 mm

Products per stick pack:

Stick Pack flat:

3 – 8 pieces

Stick Pack on edge:

3 – 16 pieces



# U1-I

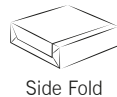

## Output

- up to 1000 products/min

## Size Range

Double Twist/

Bottom Fold:

Length: 16–45 mm

Width: 12–25 mm

Height: 4–15 mm

Ø: 8,8–15 mm

Side Fold:

Length: 25–45 mm

Width: 8–25 mm

Height: 5–15 mm

Special sizes upon request



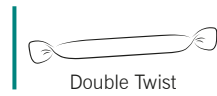

# U1-II/III



### Output

- up to 1000 products/min U1-II
- up to 900 products/min U1-III

### Size Range

#### U1-II

Length: 46– 65 mm

#### U1-III

Length: 66–100 mm

Width: 8– 25 mm

Height: 5– 15 mm

Ø: 8,8– 15 mm

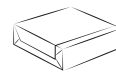

Side Fold with comic strip

# U1-EFC



### Output

- up to 1000 products/min

### Size Range

Length: 25–45 mm

Width: 12–25 mm

Height: 5–15 mm

Special sizes upon request

# U1 + F1



Bottom Fold  
Primary packaging

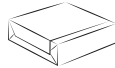

Side Fold  
Primary packaging

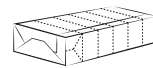

Stick Pack on edge  
Secondary packaging

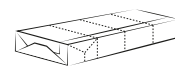

Stick Pack flat  
Secondary packaging

## Output

- up to 1000 single products/min
- up to 200 stick packs/min

## Size Range

### U1:

Length: 16– 45 mm

Width: 12– 25 mm

Height: 4– 15 mm

### F1:

Length: 25–113 mm

Width: 15– 30 mm

Height: 5– 25 mm

Special sizes upon request.

## Products per stick pack:

Stick Pack flat:

2 – 8 pieces

Stick Pack on edge:

3 – 16 pieces



# EW5



Double Twist

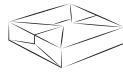

Bottom Fold

# EW8



Side Fold with comic strip

## Output

- up to 600 products/min

## Size Range

### EW5:

Length: 19–45 mm

Width: 12–25 mm

Height: 5–16 mm

Ø: 11–16 mm

### EW8:

Length: 20–45 mm

Width: 12–25 mm

Height: 5–16 mm

Width: Height >1,5



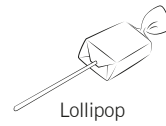

Lollipop

# EW7



Vienna-Fruit-Fold

# EW10



#### Output

##### EW7:

- up to 350 products/min

##### EW10:

- up to 300 products/min

#### Size Range

##### EW7:

Length: 30–50 mm

Width: 14–25 mm

Height: 8–14 mm

Stick length:

75–90 mm

Stick diameter:

3– 4 mm

##### EW10:

Length: 25–35 mm

Width: 16–18 mm

Height: 10–15 mm

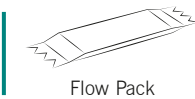

Flow Pack

# FPW5

#### Output

- up to 1500 products/min

#### Size Range

Length: 20–200 mm

Width: 12– 30 mm

Height: 3– 16 mm



Wrapping solutions for  
chocolate products, jellies,  
cereal bars and other bar  
shaped products



# CHS | MCC | EMC | FPC5 | CFW |



Double Twist



Side Twist



Top Twist



Bunch

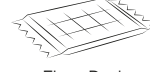

Flow Pack



Flow Pack



Envelope Fold

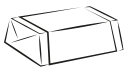

Envelope Fold  
with Banderole



Bottom Fold

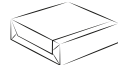

Side Fold

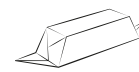

Vienna-Fruit-Fold

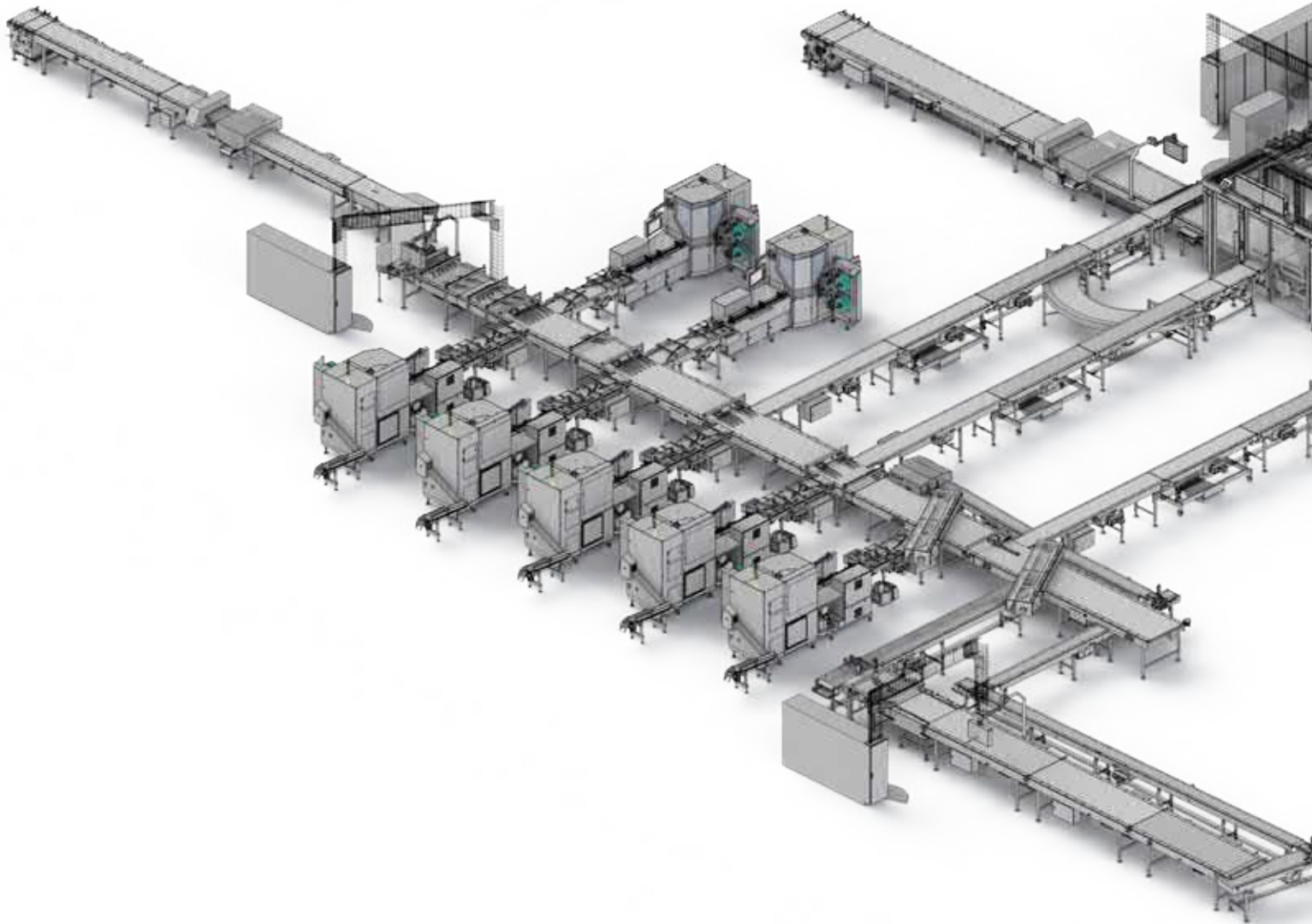



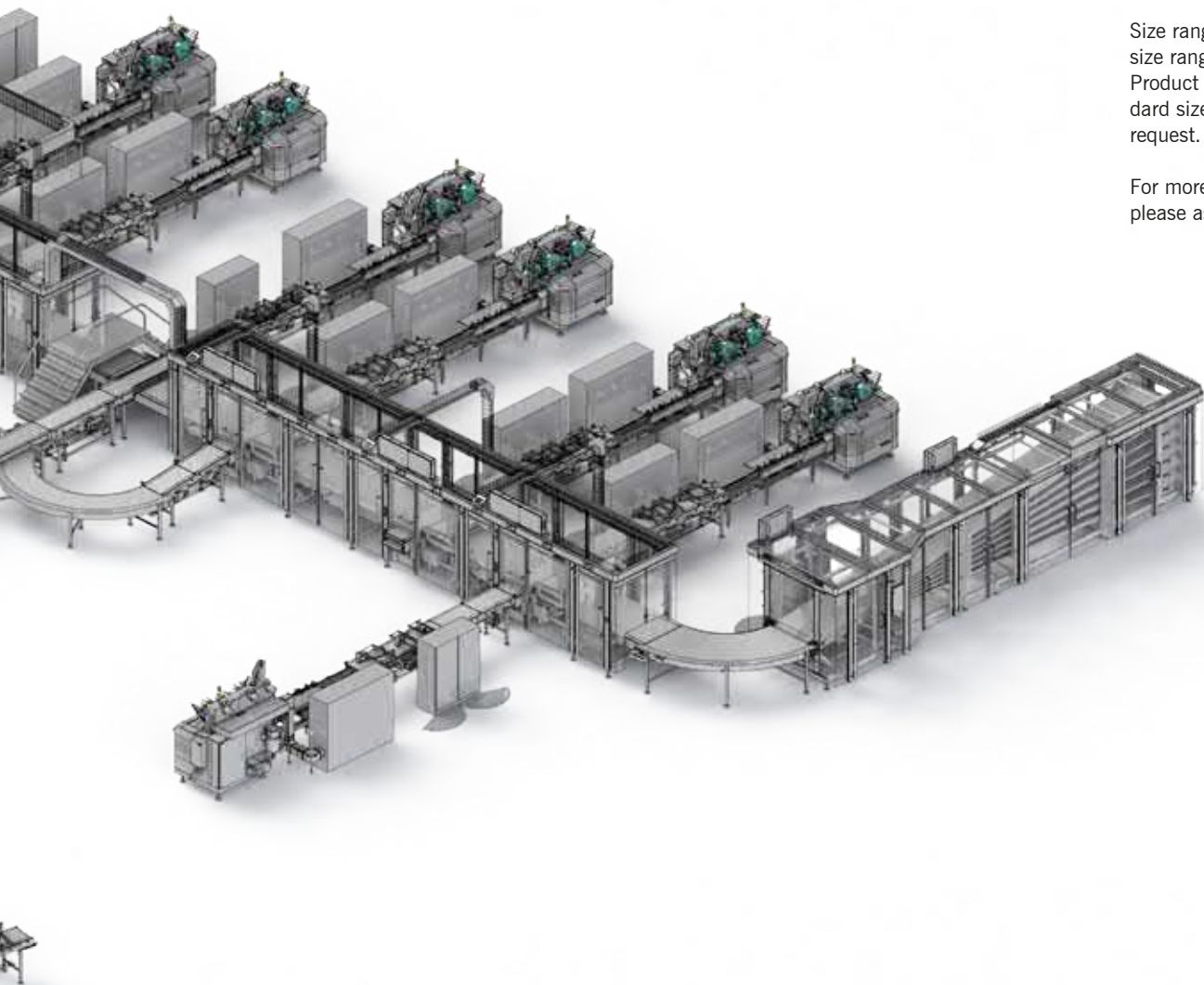

Wrapping System for chocolate products comprising:

- Distribution system with integrated fan type buffer
- Infeed and synchronisation conveyors for the wrapping machines
- Wrapping machines EMC and CWM2

Alternatively, Theegarten-Pactec machines for other wrapping styles can be connected to such systems (CHS, CFW, MCC, FPC5).

The wrapping capacities given in the individual machine specification are to be understood as maximum capacities. They may vary depending on the product size, the product consistency and the quality of the wrapping material.

Size ranges given are the standard size ranges of the equipment. Product sizes outside the standard size range remain subject to request.

For more detailed information please ask for specific brochures.

# CHS

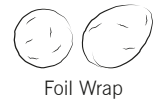

## Output

- up to 1800 products/min  
Double Twist,
- up to 1600 products/min  
Protected Twist,  
Envelope Fold
- up to 1400 products/min  
Side Twist,
- up to 1300 products/min  
Foil Wrap
- up to 1200 products/min  
Vienna-Fruit-Fold,  
Top Twist

## Size Range

- Length: 16–60 mm
- Width: 12–35 mm
- Height: 4–25 mm
- dome shaped products:  
Ø: 16–33 mm
- Height: 16–28 mm
- ball shaped products:  
Ø: 12–35 mm

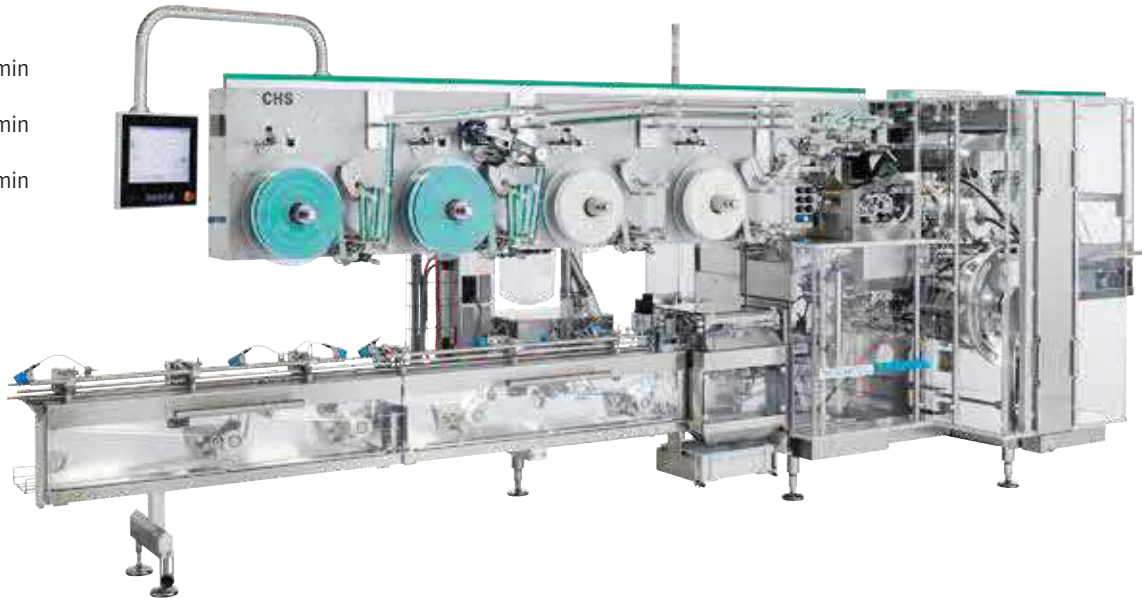

# MCC



## Output

- up to 1200 products/min  
Double Twist,  
Protected Twist and Foil Wrap
- up to 800 products/min  
Top Twist, Side Twist,  
Vienna-Fruit-Fold

## Size Range

- Length: 16–45 mm
- Width: 12–25 mm
- Height: 6–25 mm
- dome shaped products:  
Ø: 16–33 mm
- Height: 16–28 mm
- ball shaped products:  
Ø: 13–33 mm





Double Twist  
Protected Twist



Side Twist-Basket



Side Twist-Sachet



Foil Wrap

# MCH

### Output

- up to 1200 products/min  
Double Twist,  
Protected Twist and Foil Wrap
- up to 1100 products/min  
Side Twist

### Size Range

- Length: 16–45 mm
- Width: 12–25 mm
- Height: 6–25 mm
- disc shaped products:  
Height: 6–25 mm  
Ø: 13–33 mm
- ball shaped products:  
Ø: 13–33 mm

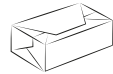

Envelope Fold

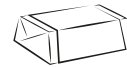

Envelope Fold  
with Banderole

# CFW-S

### Output

- up to 800 products/min

### Size Range

- Length: 25–150 mm
- Width: 15– 50 mm
- Height: 5– 25 mm



# EMC



Bunch

## Output

- up to 900 products/min

## Size Range

Length: 15–30 mm  
Width: 10–30 mm  
Height: 7–24 mm  
(Height above 24 mm upon request)  
dome shaped products  
Ø: 15–30 mm  
Height: 7–24 mm



# FPC5

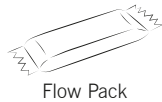

Flow Pack

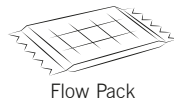

Flow Pack

## Output

- up to 1500 products/min

## Size Range

### FPC5

Length: 15–220 mm  
Width: 12– 60 mm  
Height: 4– 30 mm

### FPC5 280

Length: 35–220 mm  
Width: 15–120 mm  
Height: 4– 30 mm

ball shaped products:  
Ø: 15– 30 mm





Wrapping solutions for  
other food /  
non-food products  
and  
cartoning systems



# BCW3 | BCW-eco | FPC5-Tabs |

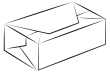

Envelope Fold

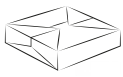

Bottom Fold



Side Fold



Cube

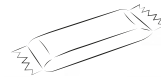

Flow Pack

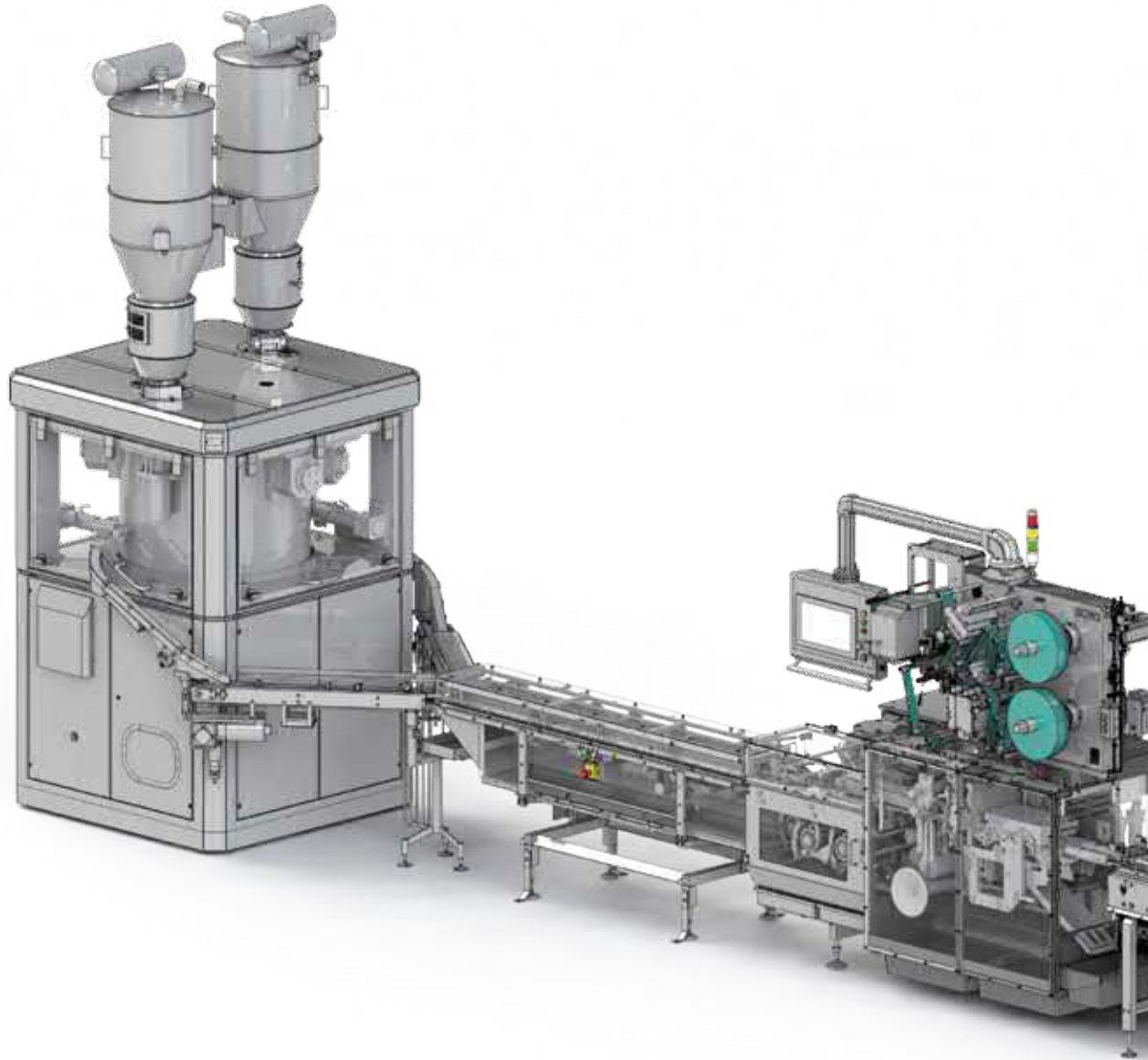



# BLM

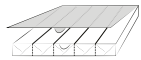

Display Carton  
single-row

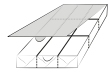

Display Carton  
multi-row

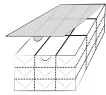

Display Carton  
multi-layer

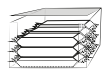

Display Carton  
multi-layer

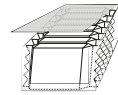

Display Carton  
upright

Processing and wrapping system for stock cubes comprising:

- Product mass feeding system to the press
- Product press for the production of stock cubes
- Wrapping machine BCW3 for fold wrapping of the stock cubes
- Packaging machine BLM for secondary packaging of the stock cubes in display cartons (multipack)

The wrapping capacities given in the individual machine specification are to be understood as maximum capacities. They may vary depending on the product size, the product consistency and the quality of the wrapping material.

Size ranges given are the standard size ranges of the equipment. Product sizes outside the standard size range remain subject to request.

For more detailed information please ask for specific brochures.

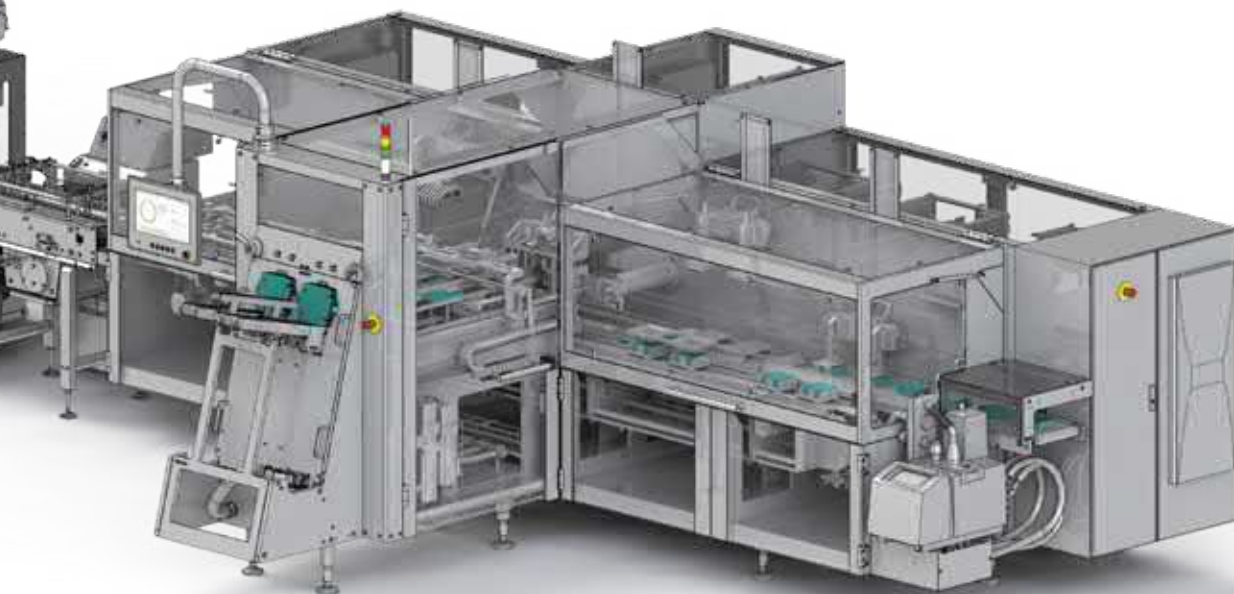

# BCW3

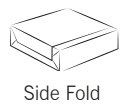
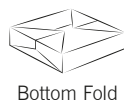

## Output

- up to 1700 products/min (preformed cubes)
- up to 1400 products/min (preformed tablets)

## Size Range

- Length: 13,5–35 mm
- Width: 13,5–25 mm
- Height: 6–20 mm
- Special sizes upon request



# BCW-eco

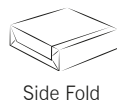

## Output

- up to 750 products/min (preformed tablets)

## Size Range

- Tablets
- Length: 28–32 mm
- Width: 22–25 mm
- Height: 8–11 mm
- Special sizes upon request



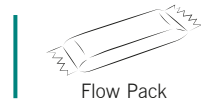

# FPC5-Tabs



**Output**  
- up to 1500 products/min

**Size Range**  
Length: 15–100 mm  
Width: 20– 60 mm  
Height: 10– 30 mm

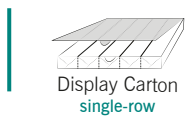

Display Carton  
single-row

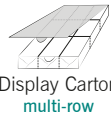

Display Carton  
multi-row

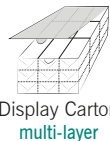

Display Carton  
multi-layer

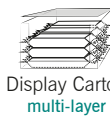

Display Carton  
multi-layer



Display Carton  
upright

# BLM

**Output**  
- up to 2000 single products/min  
- up to 120 cartons/min

**Size Range Carton**  
Length: min 75 mm  
Width: max 250 mm  
Height: max 120 mm



# EMC



Bunch

## Output

- up to 900 products/min

## Size Range

Length: 15–30 mm

Width: 10–30 mm

Height: 7–24 mm

(Height above 24 mm upon request)

dome shaped products

Ø: 15–30 mm

Height: 7–24 mm









